

XS (FR/PR)

For Flat or Pitched Roofs

Installation Manual



1.0 SAFETY INFORMATION

- The provision of the electrical supply and the connection of the unit to the electrical supply must be carried out by a qualified electrician in accordance with latest edition of the wiring regulations.
- All-pole disconnection from the mains as shown in the wiring diagram must be incorporated within the fixed wiring and shall have a minimum contact separation of 3mm in accordance with latest edition of the wiring regulations.
- Precautions must be taken to avoid the back-flow of gases into the room from the open flue of gas or other fuel-burning appliances.
- This appliance should not be used by children or persons with reduced physical, sensory or mental capabilities or lack of experience and knowledge, unless they have been given supervision or instruction concerning the safe use of the appliance by a person responsible for their safety. Children shall not play with the appliance. Cleaning and user maintenance shall not be carried out by children.

1.1 Hazard Symbols



GENERAL WARNING

Signifies a general warning regarding hazard specified by supplementary information.



ELECTRIC SHOCK

This unit must be completely electrically isolated before any panels are removed. Check mains supply and control connections.



ROTATING PARTS

This unit contains fast moving rotational parts which may start automatically. It is the sole responsibility of the installer to adequately guard these components.



REFER TO INSTRUCTION MANUAL

Read and understand the installation and maintenance manual before installing, operating or maintaining this product.

1.2 Important Information

This manual contains important information on the safe and appropriate assembly, transport, commissioning, operation, maintenance, disassembly and simple troubleshooting of the product.

While the product has been manufactured according to the accepted rules of current technology, there is still a danger of personal injury or damage to equipment if the following general safety instructions and the warnings contained in these instructions are not complied with.

- **Read these instructions completely and thoroughly before working with the product.**
- **Keep these instructions in a location where they are accessible to all users at all times.**
- **Always include the operating instructions when you pass the product on to third parties.**

1.3 Personal Protective Equipment

The following minimum Personal Protective Equipment (PPE) is recommended when interacting with Nuaire product:

- **Protective Steel Toed Shoes** - when handling heavy objects.
- **Full Finger Gloves (Marigold PU800 or equivalent)** - when handling sheet metal components.
- **Semi Fingerless Gloves (Marigold PU3000 3DO or equivalent)** - when conducting light work on the unit requiring tactile dexterity.
- **Safety Glasses** - when conducting any cleaning/cutting operation or exchanging filters.
- **Reusable Half Mask Respirators** - when replacing filters which have been in contact with normal room or environmental air.

Nuaire would always recommend a site specific risk assessment by a competent person to determine if any additional PPE is required.

2.0 INTRODUCTION

The Nuaire XS Roof Fan Kit is available in 6, 9 and 12 inch impeller sizes suitable for supply or extract and can form the heart of an automatic ventilation system.

Ensure adequate air replacement for the fan and any fuel burning appliance in the room.

Two types of roof fan kits are available, one for a flat roof and the other to cover a pitched roof installation.

The applications are ideally suitable for direct ventilation of a top storey area.

The fan is IP24 splash proof approved with the motor rated at IP44. Roof Terminal components are made in soft grey colours from ultra violet stable Styrosun so they will blend with most decors and will not fade in sunlight.

Roof Fan Kits are supplied as a complete package with all installation parts included.

1 Typical Installation On Flat Roof Upstand, Direct Ventilation

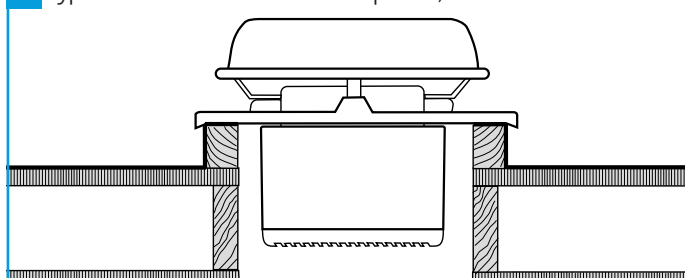

2 Typical Installation On Pitched Roof Upstand, Direct Ventilation

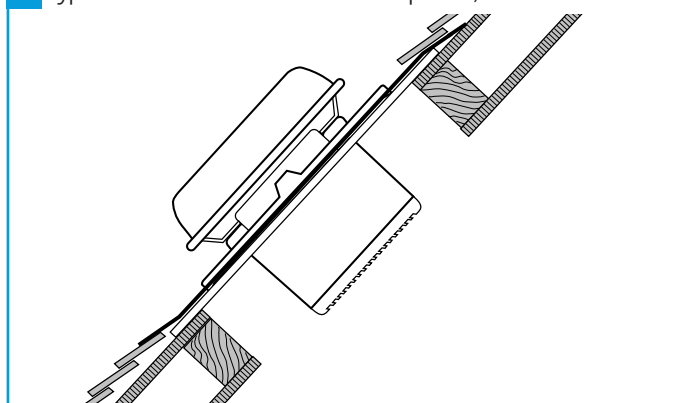

2.1 Code Description:

XS	6	FR	H
1	2	3	14

1. Range: **XS**
2. Unit Size: **6, 9, 12**
3. Roof Type: **FR** = Flat Roof
PR = Pitched Roof

Electrical Frequency: **No Suffix** = 50Hz
H = 60Hz (220V)

2.2 General Dimensions (mm)

3 Dimensions

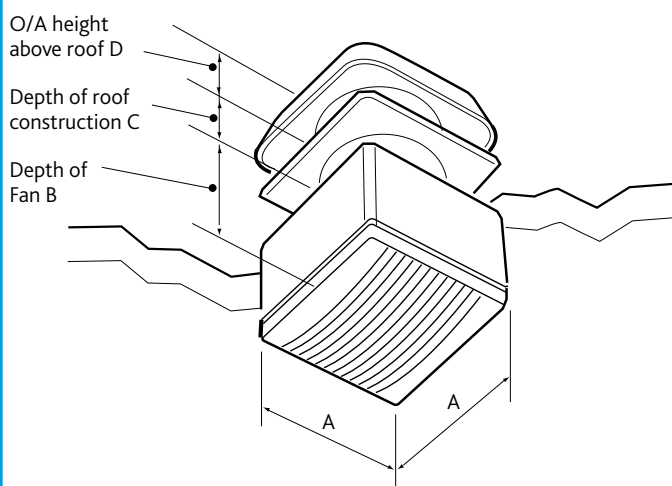

XS Unit	A	B	C*	D
6"	269	161	150	170
9"	337	158	150	180
12"	413	172	150	185

2.3 Unit Weights (kg)

Model	Weight (kg)
XS6FR supply & extract	6.3
XS6PR supply & extract	6.3
XS9FR supply & extract	8.7
XS9PR supply & extract	9.1
XS12FR supply & extract	11.0
XS12PR supply & extract	11.8

2.4 Switch

Operated via a separately wired fused spur (by others) or operated via the optional XS-MFC remote controller allowing supply or extract, variable speed and automatic or manual switching of several fans if desired.

2.5 Sensors

Sensors are available as remote units or integral 'plug in' units. They are able to control multiple fans, depending on sensor and fan types. Integral sensors are quick and easy to install and are aesthetically pleasing, whilst remote sensors give the benefit of location close to the pollutant source.

Remote Sensors should be positioned at least 1.5m above the floor and away from direct sources of heat such as radiators etc.

Options include: Humidity, Air Quality, Passive Infra Red, Temperature and Timer versions.

3.0 MECHANICAL INSTALLATION

Installation must be completed by competent persons, in accordance with good industry practice and should conform to all governing and statutory bodies i.e. IEE, CIBSE, etc.

Before commencing work, make sure that the unit is electrically isolated from the mains supply.

3.1 Flat Roof Kit

Prepare a timber or builders work upstand on the roof to the dimensions below. Carry roof felt or weathering material over the curb to ensure a good seal. The kit is supplied with the fan, spacer and grille assembled for transit purposes. The instructions opposite assume the fan assembly has been separated to begin the installation.

4 Flat Roof Upstand Construction Details

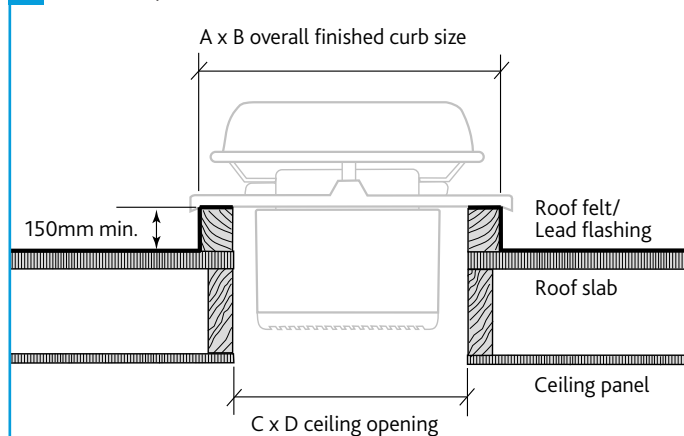

Fan Code	A	B	C	D
XS6FR	610	610	300	300
XS9FR	610	610	450	450
XS12FR	695	695	450	450

5 Flat Roof Kit Exploded Assembly

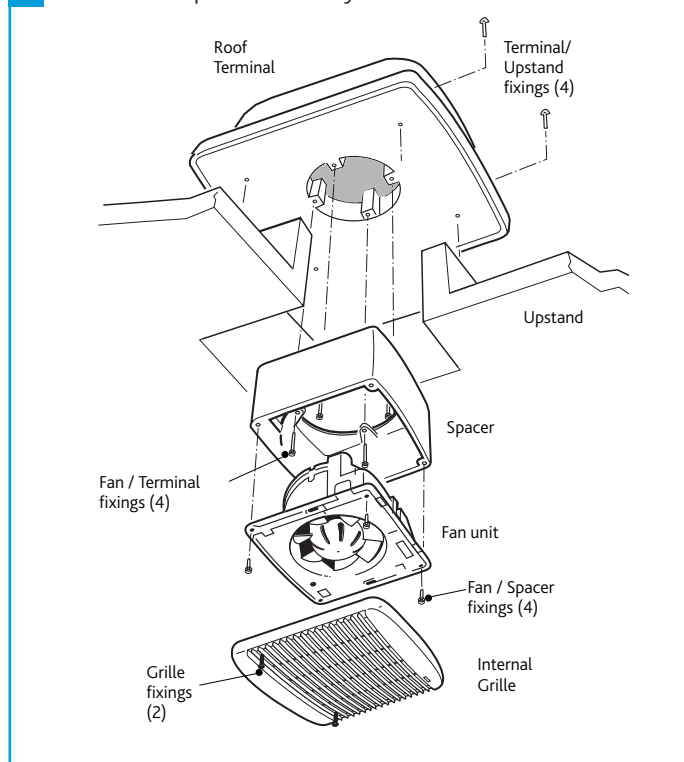

6 Flat Roof Installation - 1

Drill through the dimples in the Roof Terminal.

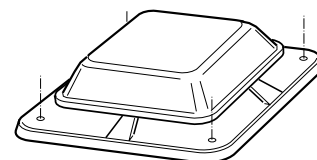

7 Flat Roof Installation - 2

Position centrally & squarely over curb and fix using 6mm wood screws and sealing washers.

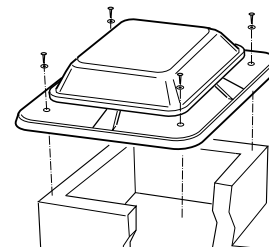

8 Flat Roof Installation - 3

Feed the supply cable through the spacer.

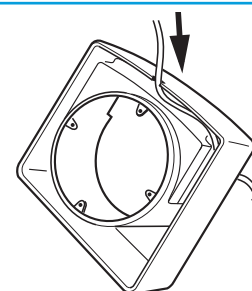

9 Flat Roof Installation - 4

Offer up the spacer section to the terminal underside and fix using the 4, 5mm screws provided.

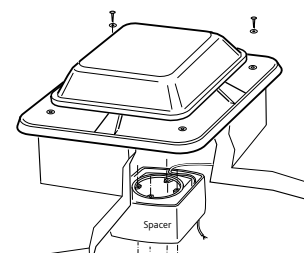

10 Flat Roof Installation - 5

Release the electrical cover from the fan plate.

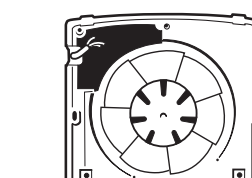
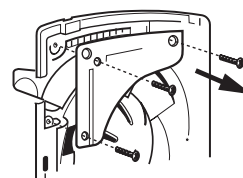

For various wiring options see wiring details page 4.

11 Flat Roof Installation - 6

Assemble the fan to the spacer section 4 panhead screws.

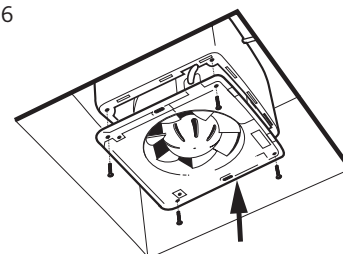

12 Flat Roof Installation - 7

Fit the grille to the fan, locating top lip before fixing.

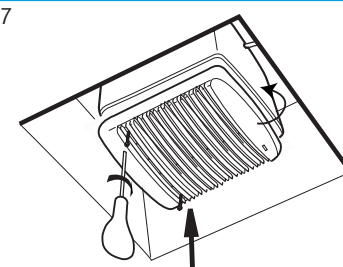

3.2 Pitched Roof Kit

Prepare a timber or builders work upstand on the roof to the dimensions below. Carry roof felt or weathering material over the curb to ensure a good seal. The kit is supplied with the fan, spacer and grille assembled for transit purposes. The instructions opposite assume the fan assembly has been separated to begin the installation.

13 Pitched Roof Aperture Details

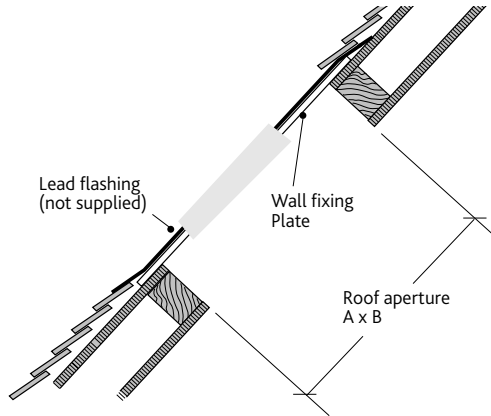

Fan Code	A	B	C	D
XS6PR	610	610	300	300
XS9PR	610	610	450	450
XS12PR	695	695	450	450

14 Pitched Roof Kit Exploded Assembly

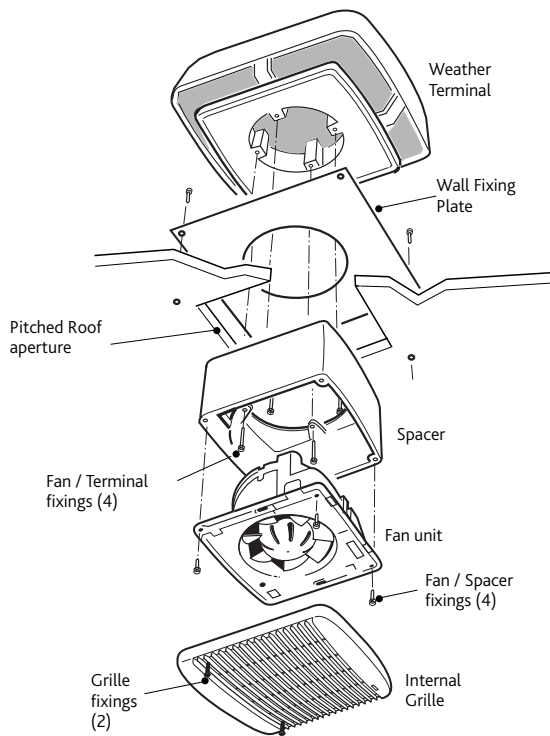

15 Pitched Roof Installation - 1

Fix the Wall Fixing Plate centrally over the roof aperture. Screws not provided.

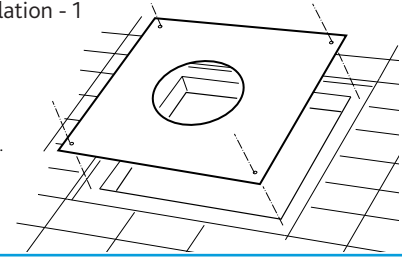

16 Pitched Roof Installation - 2

Locate the Weather terminal centrally over the plate. Use the foam adhesive strips to secure temporarily.

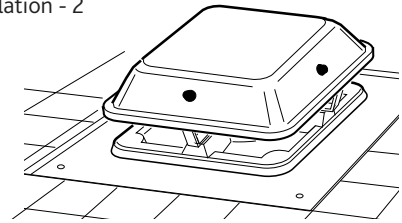

17 Pitched Roof Installation - 3

Feed the supply cable through the spacer.

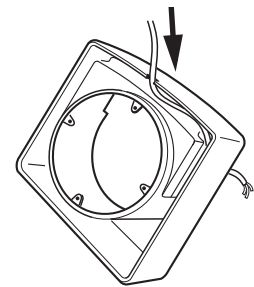

18 Pitched Roof Installation - 4

Offer the spacer section up and fix through to the weather terminal fixing inserts.

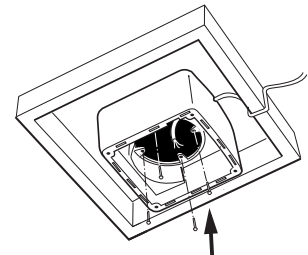

19 Pitched Roof Installation - 5

Seal the joint edge all round with sealing mastic to ensure adequate weathering. Alternatively use lead flashing.

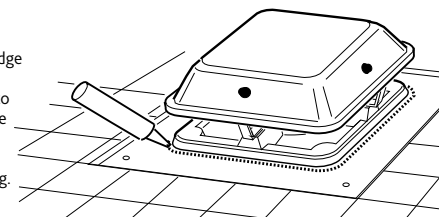

20 Pitched Roof Installation - 6

Release the electrical cover from the fan plate.

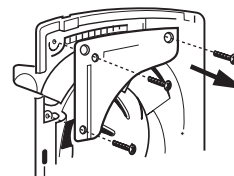

For various wiring options see wiring details page 6.

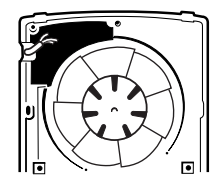

21 Pitched Roof Installation - 7

Assemble the fan to the spacer section 4 set screws.

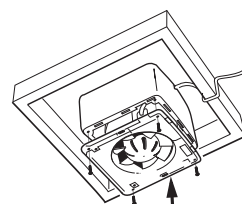

Fit the grille to the fan, locating top lip before fixing.

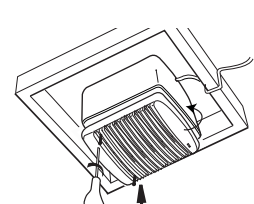

4.0 ELECTRICAL INSTALLATION

The provision of the electrical supply and the connection of the unit to the electrical supply must be carried out by a qualified electrician in accordance with latest edition of the wiring regulations.

All-pole disconnection from the mains as shown in the wiring diagram must be incorporated within the fixed wiring and shall have a minimum contact separation of 3mm in accordance with latest edition of the wiring regulations.

22 Electrical Panel Installation - 1

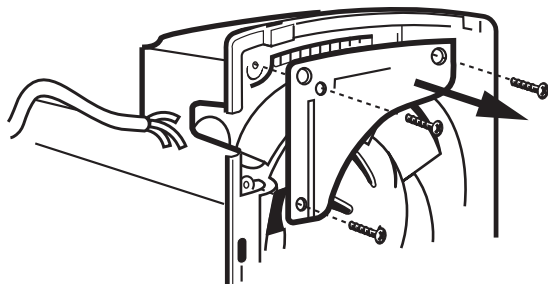

Release the electrical panel from the fan plate.

23 Electrical Panel Installation - 2

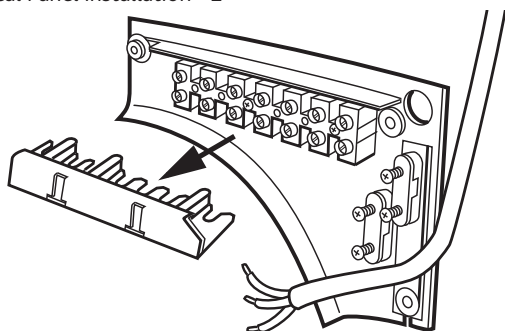

Remove the terminal cover.

24 Electrical Panel Installation - 3

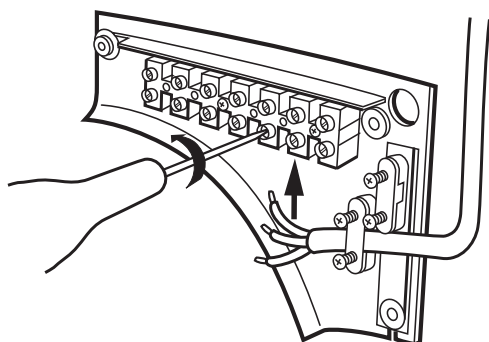

25 Electrical Panel Installation - 4

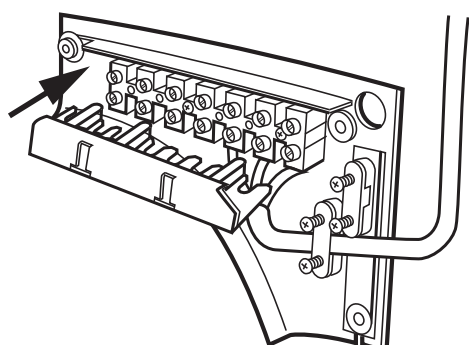

4.1 Electrical Specification

230V ~ 50Hz / 220V ~ 60Hz Class I. Motor thermally protected by overload device. Cable: 1mm max. or min. Fuse: 3 amp (if fan is supplied from a 5A lighting circuit, no local fuse is required).

If 2 x 12 inch fans or 3 x 6 or 9 inch fans are used in the same operating mode in the same room they should all be controlled from the same MFC speed control. This avoids the possibility of one fan (if speed controlled at a lower flow rate) being stalled by the other fan(s).

Adequate make-up air provision sufficient to provide ventilation in accordance with building regulations is required in all rooms. This should be checked during commissioning with all fans in the same room running together in all possible configurations.

The automatic shutters, motor bearings should be frequently inspected and maintained to ensure they open fully/operate satisfactorily. Use of an RCD and fused spur with 1A, Bussmann TDC180, BS1362, fuse (Farnell order no: 1123029) for 1 fan or 2A, Bussmann TDC180, BS1362 fuse (Farnell order no: 1123032) for 2 or 3 fans is recommended.

Always confirm airflow direction before commissioning.

4.2 Electrical Information

Model	Input Power (W)*		Weight (kg)
	Max.	Economy	
XS6FR	38	20	6.3
XS6PR	38	20	6.3
XS9FR	50	37	8.7
XS9PR	50	37	9.1
XS12FR	100	70	11.0
XS12PR	100	70	11.8

*Figures shown are for extract airflow only when electrical frequency = 50Hz.

4.3 Shutter Operation

There will be a short delay on startup and shutdown of approximately 40 seconds, this is normal.

4.4 Wiring Diagrams

4.4.1 On / Off Switch Operation

- Connect link wire between L2 & L4 for extract **OR** Connect link wire between L2 & L3 for supply.

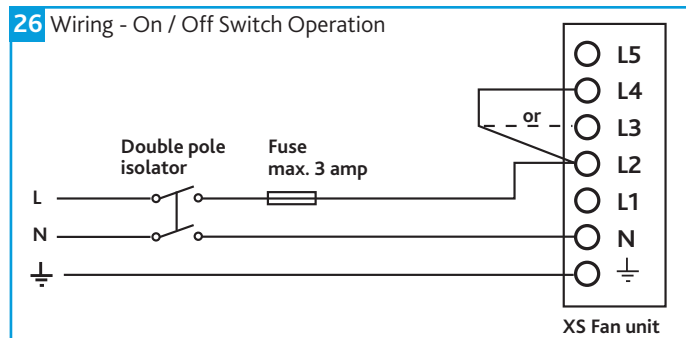

4.4.2 Integral Sensor Operation

- Connect link wire between L2 & L4 for extract **OR** connect link wire between L2 & L3 for supply.
- Connect switched live signal to L5 for integral timer module.

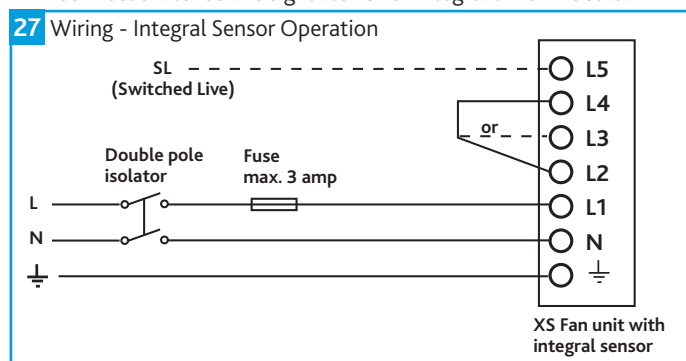

4.4.3 Remote Sensor Operation

- Connect link wire between L2 & L4 for extract **OR** connect link wire between L2 & L3 for supply.

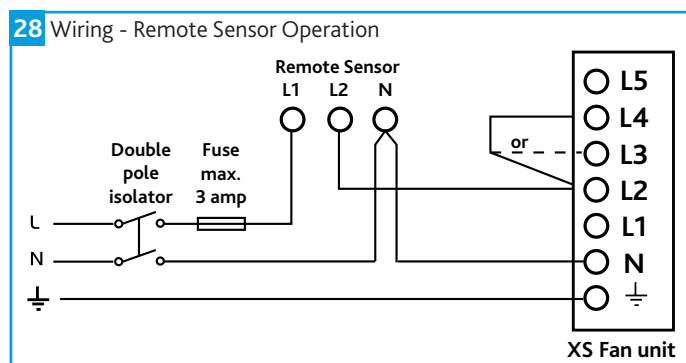

4.4.4 XS-MFC Remote Control Operation

Remote switch may be set: On/Off, Forward/Reverse, Economy/Std. (variable speed), Auto/Manual.

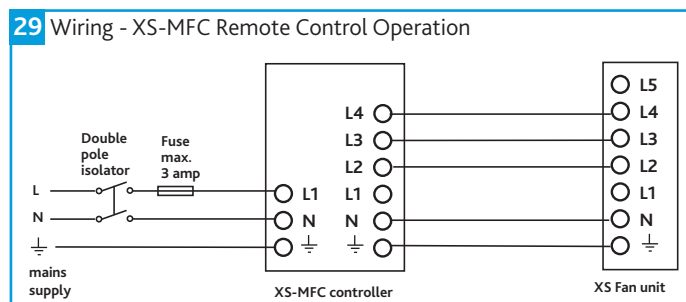

4.4.5 XS-MFC Remote Control With Integral Sensor Operation

Remote switch may be set: On/Off, Forward/Reverse, Economy/Std. (variable speed), Auto/Manual.

One or more Remote Sensors may be wired in parallel to one XS-MFC Control.

Humidity Sensor: **XS-HR**

Air Quality Sensor: **XS-AQR**

Passive Infra-Red Sensor: **XS-PIRR**

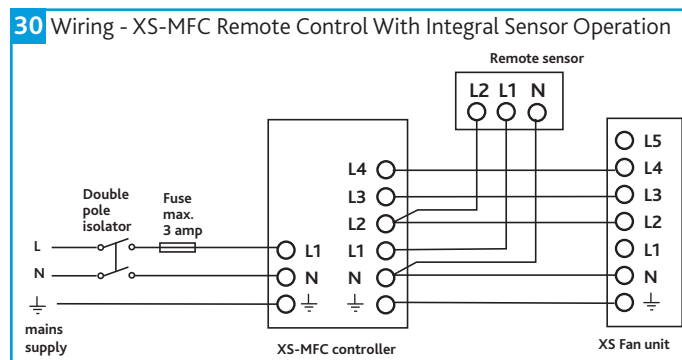

4.4.6 XS-MFC Remote Control With Remote Sensor Operation

Remote switch may be set: On/Off, Forward/Reverse, Economy/Std. (variable speed), Auto/Manual.

Maximum one Integral Sensor per fan, 6/9/12 denotes unit size identity.

Humidity Sensor: **XS-H6, XS-H9, XS-H12**

Air Quality Sensor: **XS-AQ6, XS-AQ9, XS-AQ12**

Passive Infra Red Sensor: **XS-PIR6, XS-PIR9, XS-PIR12**

Temperature Sensor: **XS-TH6, XS-TH9, XS-TH12**

Run on Timer: **XS-TA6, XS-TA9, XS-TA12**

A single sensor will switch all fans if more than one fan is being operated by a single XS-MFC controller.

Multi-fan options:

Up to 5 fans (size 6"/9") can be controlled by one XS-MFC.

Up to 2 fans (size 12") can be controlled by one XS-MFC.

Do not mix different fan sizes on the same controller.

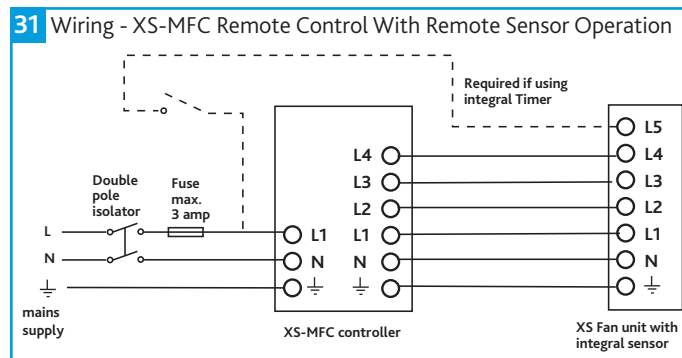

4.5 Integral Sensor Installation (Optional)

Before following the pictorial sequence shown, first remove the fans front cover grille (2 screws). Release the four main corner screws and lift out the motor/fan plate assembly. Remove the electrical cover plate opposite the sensor plate. Follow the pictorial sequence on this page.

32 Integral Sensor Installation - 1

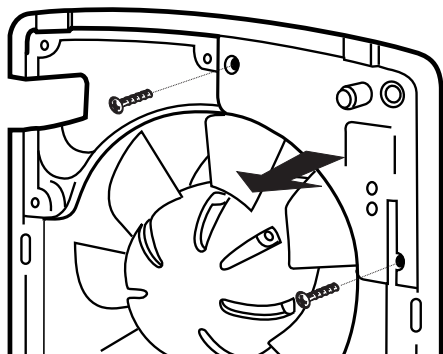

Unscrew the module plate from motor plate assembly.

33 Integral Sensor Installation - 2

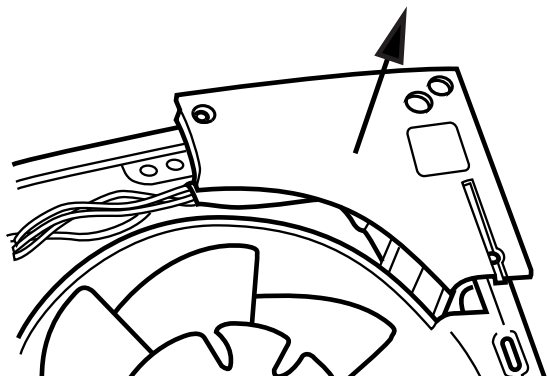

Remove the module plate.

34 Integral Sensor Installation - 3

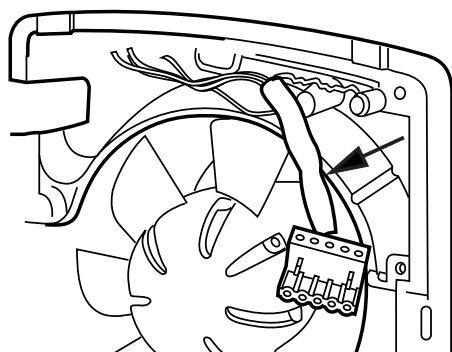

Lift out the sensor module wiring connector.

35 Integral Sensor Installation - 4

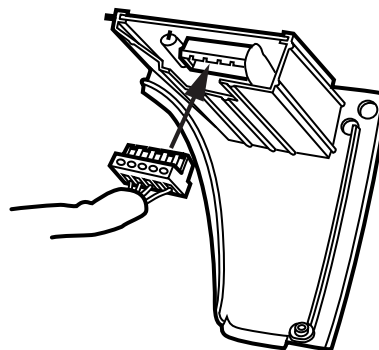

Plug the connector into the required sensor module.

36 Integral Sensor Installation - 5

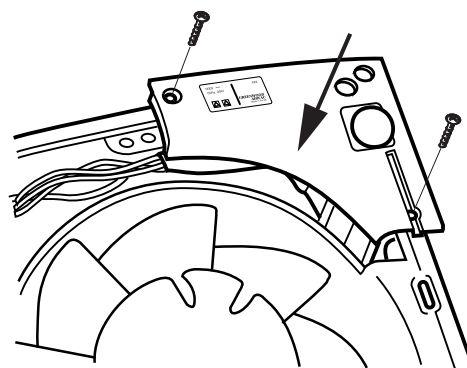

Screw the sensor module into position.

37 Integral Sensor Installation - 6

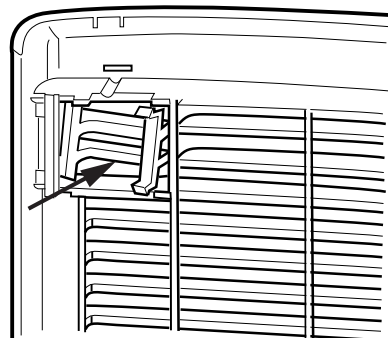

Push out the sensor area cover from the grille.

38 Integral Sensor Installation - 7

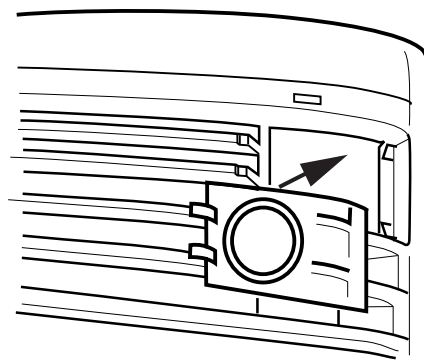

Push the replacement cover into the grille front.

4.6 XS-MFC Remote Control Or Remote Sensors Installation (Optional)

The XS-MFC Multi Fan Control provides supply or extract, variable speed and automatic or manual switching of several fans if desired, (see note below). The control is best mounted approx 1.5m above the floor. Remote Sensors are available for Humidity, Air Quality and Passive Infra Red control. Remote Sensors should be positioned at least 1.5m above the floor and away from direct heat sources e.g. radiators.

Up to 5 fans (size 6 / 9 inch) can be controlled by one XS-MFC.

Up to 2 fans (size 12 inch) can be controlled by one XS-MFC.

Do not mix different fan sizes on the same controller.

39 Remote Control / Sensor Installation - 1

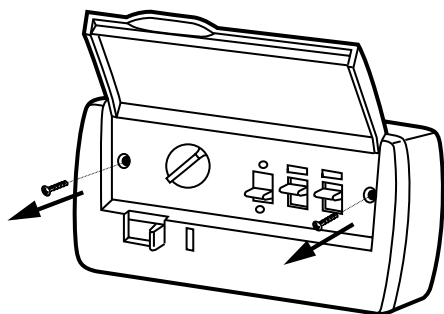

Lift up panel and remove two screws to dismantle unit.

40 Remote Control / Sensor Installation - 2

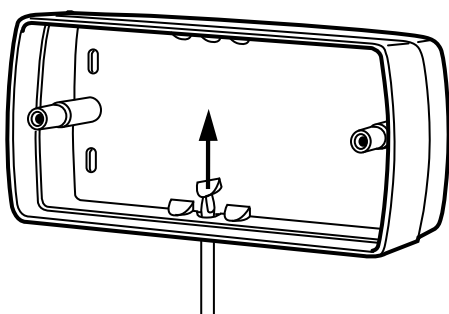

Push out backplate box cable entry using a screwdriver.

41 Remote Control / Sensor Installation - 3

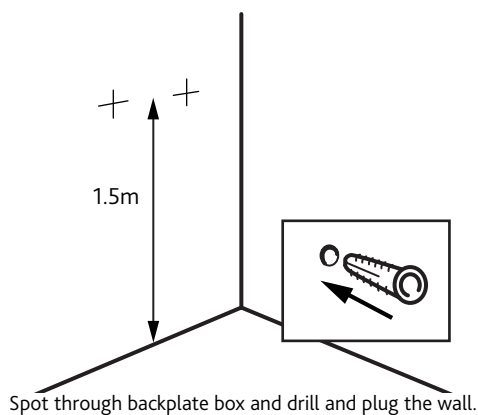

Spot through backplate box and drill and plug the wall.

42 Remote Control / Sensor Installation - 4

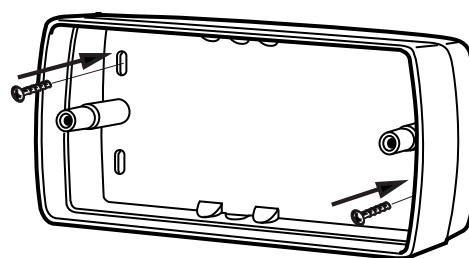

Fix backplate box to the prepared wall.

43 Remote Control / Sensor Installation - 5

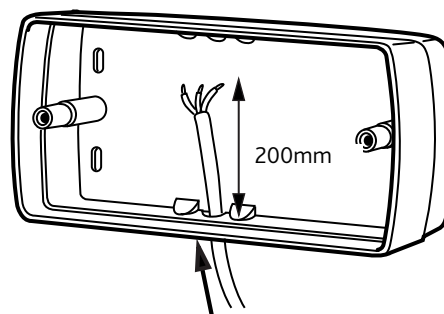

Feed approx. 200mm of supply cable into the box.

44 Remote Control / Sensor Installation - 6

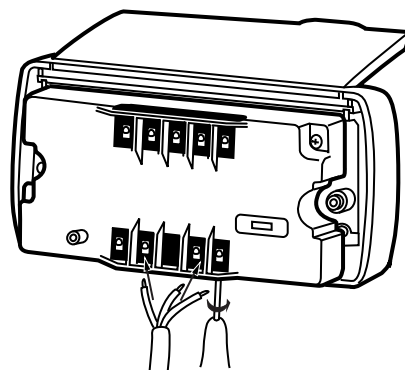

Connect the end of the cable into the control block.

45 Remote Control / Sensor Installation - 7

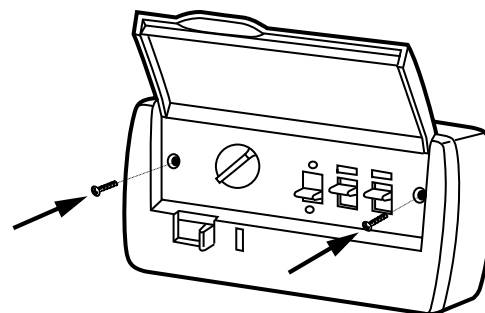

Fit the control into the backplate box and secure. Test the installation.

5.0 ANCILLARIES

5.1 Single Spigot Adaptor

Used in conjunction with flexible ducting systems.

Mounted onto the front of the Spacer section using the 4 off 5mm x 40mm brass screws supplied with the Single Spigot Adaptor. Replaces the internal grille.

Can also be used connected directly to a Roof Terminal using the 4 off 5mm x 40mm brass screws supplied with the Single Spigot Adaptor. Manufactured from HIPS material.

46 Single Spigot Adaptor



5.2 Flexible Ducting & Installation Accessories

A full range of ducting and installation accessories is available from Nuair. Call Nuair on 02920 885231 to request literature.

47 Flexible Ducting

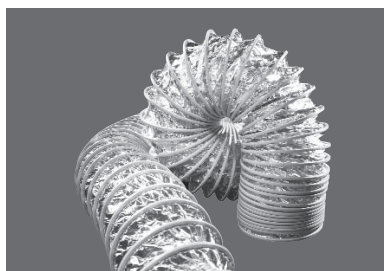

6.0 MAINTENANCE

It is important that maintenance checks are recorded and that the schedule is always adhered to, in all cases, the previous report should be referred to.

6.1 Routine Maintenance

Periodically, at least once a year or more frequently in case of heavy use, remove the dirt and encrustation from the grille(s) fan impeller and motor casing. Ensure the impeller is not cracked or deformed and is able to rotate freely and without oscillation.

Do not use any solvents to clean this product.

7.0 WARRANTY

The 3 year warranty starts from the day of delivery and includes parts and labour for the first year. The remaining period covers replacement parts only.

This warranty is void if the equipment is modified without authorisation, is incorrectly applied, misused, disassembled, or not installed, commissioned and maintained in accordance with the details contained in this manual and general good practice.

The product warranty applies to the UK mainland and in accordance with Clause 14 of our Conditions of Sale. Customers purchasing from outside of the UK should contact Nuair International Sales office for further details.

Failure to maintain the unit as recommended will invalidate the warranty.

8.0 END-OF-LIFE AND RECYCLING

Where possible Nuair use components which can be largely recycled when the product reaches its end-of-life:

- Fans, motors, controls, actuators, cabling and other electrical components can be segregated into WEEE recycling streams.
- Sheet metal parts, aluminium extrusion, heating/cooling coils and other metallic items can be segregated and fully recycled.
- EPP, plastic ducting, nylon corner pieces, plastic heat exchangers, packaging material and other plastic components can be segregated into mixed plastic and widely recycled.
- Cardboard packaging, wood, used filters and other paper components can be largely recycled or fully processed in energy from waste centres.
- Remaining Items can be further segregated and processed in accordance with the zero waste hierarchy. Please call After Sales Support for further information on items not listed above.

Ensure that Nuair product is made safe from any electrical / water / refrigerant supplies before dismantling commences. This work should only be undertaken by a qualified person in accordance with local authority regulations and guidelines, taking into account all site based risks.

9.0 AFTER SALES AND REPLACEMENT PARTS

For technical assistance or further product information, including spare parts and replacement components, please contact the After Sales Department.

If ordering spares please quote the serial number of the unit together with the part number, if the part number is not known please give a full description of the part required. The serial number will be found on the identification plate attached to the unit casing.

Telephone 02920 858 400
aftersales@nuair.co.uk

Technical or commercial considerations may, from time to time, make it necessary to alter the design, performance and dimensions of equipment and the right is reserved to make such changes without prior notice.

