



XTRACTOR (ESX) 1 and 3 phase, Direct Drive, Fans for indoor use

Installation and Maintenance

INDOOR USE ONLY

Introduction

Units are rectangular in section and have circular/rectangular rigid spigots at each end. Four matching mounting feet are supplied with the unit.

Full size access panels are fitted to the top and bottom faces. These panels are fully detachable for inspection purposes.

The models are coded as follows:

- ESXL** (Low profile Internal Duct Mounted).
- ESX** (Internal Duct Mounted).
- ESXH** (Internal Duct Mounted with High efficiency motor).

Fig. 1 General view of a typical unit.

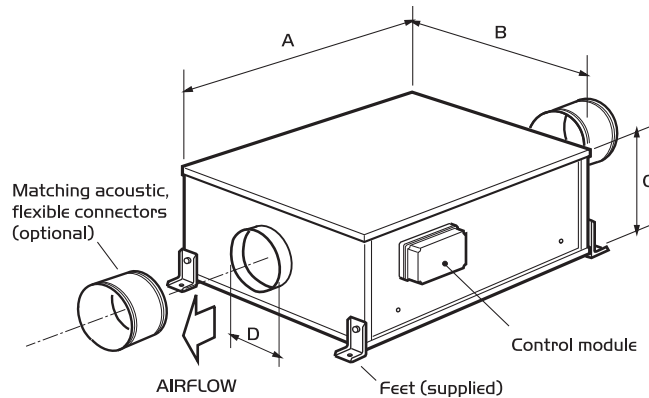

Table I. Dimensions (mm)

Code	A	B	C	Spigot D dia.	Rectangular Spigot		Weight Kg
					E	F	
ESXLI	1063	650	352	250	-	-	-
ESXL2-DS	1006	1000	350	-	500	250	118
ESXL3-DS	1006	1000	350	-	500	250	118
ESXL4-DS	1006	1000	350	-	500	250	118
ESXI-DS	328	462	266	150	-	-	14
ESX2-DS	373	524	340	200	-	-	19
ESX2H-DS	373	524	340	200	-	-	19
ESX3-DS	432	570	405	200	-	-	29
ESX4-DS*	563	807	481	250	-	-	46
ESX5-DS	563	807	481	400	-	-	49
ESX6-DS	563	807	481	400	-	-	57
ESX6H-DS	563	807	481	400	-	-	60
ESX9-DS	655	840	630	500	-	-	97
ESX9H-DS	655	840	630	500	-	-	94

*(ESX4-DS = Single phase unit). DS = Double skin casework.

Code	A	B	C	Spigot D dia.	Weight Kg
ESXI	763	572	210	150	18
ESX2	778	787	262	200	26
ESX3	913	787	340	200	37
ESX4	1063	1047	360	250	48
ESX5	1193	1047	423	400	58
ESX6	1193	1047	423	400	63
ESX9	1195	1174	575	500	125

Handling

Handle the units carefully to avoid damage and distortion. If mechanical aids are used to lift the unit, spreaders should be employed and positioned so as to prevent the slings, webbing etc. making contact with the casing.

Installation

The installation must be carried out by competent personnel in accordance with the appropriate authority and conforming to all statutory and governing regulations.

Units ESX I-9 and ESXLI can be mounted in any attitude except vertical with the outlet facing down, or inverted i.e. upside down as in these attitudes the shutters will not operate.

(ESX-DS Double Skin units can be mounted at any angle).

Units are supplied for installation into In-line ductwork (internal) applications. The mounting feet can be employed in surface or suspended applications.

Fig. 2 Installation guide

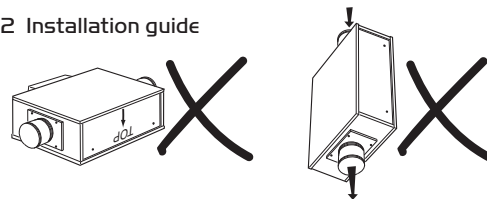

ESX I-9 and ESXLI units must NOT be installed inverted (upside down)

ESX I-9 and ESXLI units must NOT be installed with the outlet facing downward

Units should always be positioned with sufficient space to allow removal of the access covers and subsequent removal of fan and motor assemblies etc.

Ductwork connections must be airtight to prevent loss of performance. The method of mounting used is the total responsibility of the installer. The unit has an external case side mounted control module/terminal box and is supplied ready for connection into the electrical supply. If necessary, the module can be located on the other side of the unit (fixings by others).

Rigid Mounting - Note, the unit case has captive M8 nuts which can be used after removing the M8 'plugging' screws.

Fig. 3 A.V. mounting (typical)

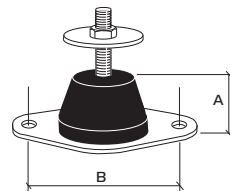

Table 2.

Code	A	B
NAVI	30	50
NAV2	40	75
NAV3	40	75
NAV4	40	75
NAV5	40	75
NAV6	50	100

On Resilient Mountings - Suspension rods / fixing screws are not supplied. Note that the large round washers included in the resilient mounting kits are for fitting above or below the resilient mounting as required to safeguard the installation against break-up of, or damage to, a mounting. In the event of a resilient mounting failure the washer will support the weight of the unit.

Suspended from ceiling - Large washers should be fitted BELOW the resilient mounts.

Electrical Detail

Because the run and start currents depend upon the duty and associated ductwork of an individual unit, run currents will be exceeded if the unit is operated with its cover removed. It is therefore recommended that the unit is not run for prolonged periods in this condition.

IMPORTANT

Isolation - Before commencing work make sure that the unit, switched live and Nuair control are electrically isolated from the mains supply.

Testing after installation

Ensure that the Fan unit and any specified controls are fitted securely according to the instructions.

Switch on the mains supply. push the test button to run each fan and check that they run satisfactorily.

If a switched live signal is used, activate this signal and check that the fan runs. De-activate the switched live signal and check the run-on-time; adjust if necessary.

Adjust the set point of any sensors and PIR; check that they function correctly.

Adjust the maximum and minimum airflow (if required) by following the commissioning procedures.

Motor Electrical Information Table 3.

230V single phase 50Hz only

Unit Code	Fuse rating	Unit Code	Fuse rating
ESXLI	3.15A	ESX 1	2A
ESXL2-DS	8A	ESX 2	2A
ESXL3-DS	10A	ESX 3	3.15A
ESXI-DS	2A	ESX 4	3.15A
ESX2-DS	2A	ESX 5	6A
ESX3-DS	3.15A	ESX 6	8A
ESX4-DS	3.15A	ESX 9	10A

230V three phase 50Hz only

Unit Code	Fuse rating
ESXL4-DS	5A

Wiring Connections

Fig. 4 Control connection Single Phase.

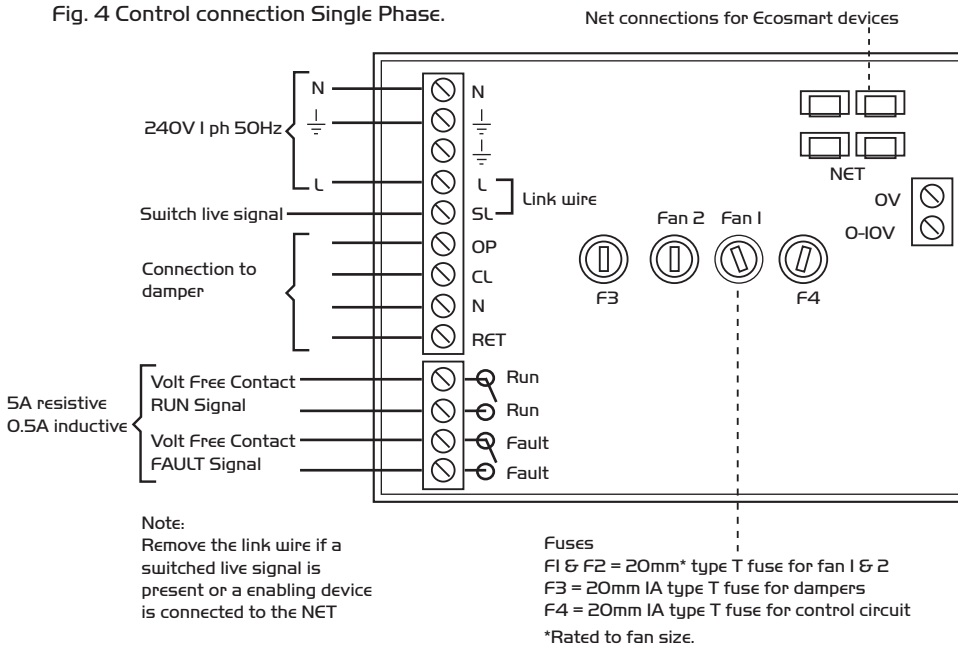
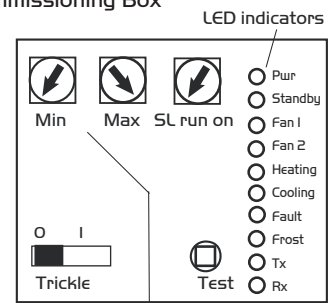
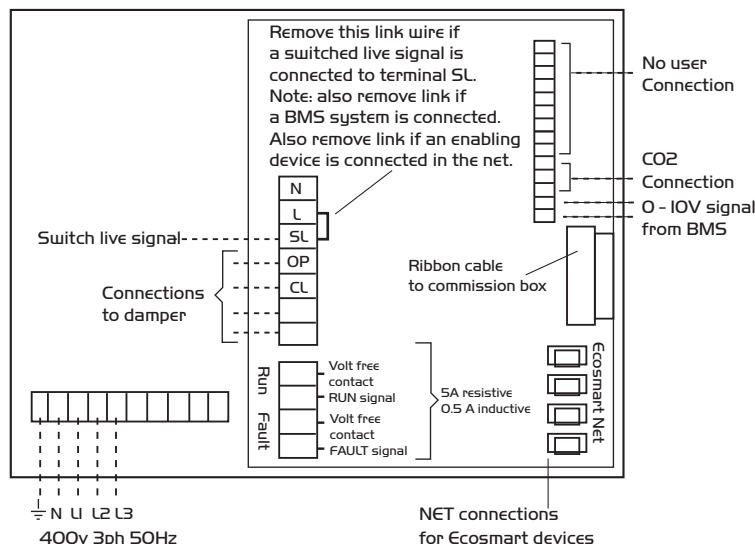

Fig. 7 Set up/ Commissioning Box



- MIN = Minimum speed adjustment
- MAX = Maximum speed adjustment
- SL Run on = Switched Live Run-On Timer adjustment
- TRICKLE = Selects trickle running. 0 = off, 1 = selected
- TEST = Test button

Fig. 6 Three Phase



I.O Connections

a) Control Connections (see fig. 4).

Net - the 4 IDC plug-in connectors are provided for the connection of compatible sensors, manual controls and for linking the fans together under a common control. If more than 4 connections are required, junction box (product code ES-JB) should be used. See 'd' Data Cable Installation below.

Switch Live (SL) terminal - A signal of 100 - 230V a.c. will activate the fan.

Note that a signal from an isolating transformer will produce an unpredictable result and is not recommended.

b) Damper connections

OP - 230V 50Hz IA max supply to open the damper

CL - 230V 50Hz IA max supply to close the damper

N - Neutral supply to damper

RET - 230V ac return signal from the damper limit switch to indicate the damper has reached its operating position. If the return signal is not present, the fan will wait for 1 minute before starting.

Note: If a damper is not fitted, connect a link wire from OP to RET. This will cancel the delay.

c) Volt Free Relay Contacts

Note that the volt free contacts are not fused. If these are used to power any external equipment, the installer must provide adequate fusing or other protections.

These contacts are rated at 5A resistive, 0.5A inductive.

Run connections - These contacts are closed when the fan is running.

Fault connections - No fault = the contacts are closed.

Fault = the contacts are opened (this includes no power supply at the unit).

d) Data Cable installation

A 4-core SELV data cable is used to connect devices such as sensors to the fan and for interconnecting multiple fan units.

Do not run data cable in the same conduit as the mains cables and ensure there is a 50mm separation between the data cable and other cables.

The maximum cable run between any two devices is 300m when it is installed in accordance with the instructions.

Please note that the total data cable length used in any system must be less than 1000m. Keep the number of cable joints to a minimum to ensure the best data transmission efficiency between devices.

e) Maximum number of devices

The maximum number of devices (including fans) that can be connected together via the data cable is 32, irrespective of their functions.

2.0 Using the Test button

The test button allows the individual blowers within the unit to be checked for its operation. If the fan is running already, press the button once to stop the fan, press again to switch on the standby fan, press again to stop and so on.

Note that the fan will return to normal operation after 30 seconds.

3.0 LED Indication

PWR GREEN: Power on & OK. RED: Too much power is taken by peripherals or there is a short circuit in the net cable. Check the cable and use a junction box (ES-JB) to connect some of the peripherals.

Standby LED on when fan is not running.

Fan I GREEN: Fan I is running, RED: Fan I faulty.

Fan 2 GREEN: Fan 2 is running, RED: Fan 2 faulty.

Heating* Not applicable. See note.

Cooling* Not applicable. See note.

Fault LED on when a fault is present on unit.

Frost* Not applicable. See note.

Tx LED on when the controller is transmitting data.

Rx LED on when the controller is receiving data.

*** Note that the control panel is common to all the Ecosmart products and will have indicators for functions that are not available in this particular fan. However these indicators will not be illuminated.**

4.0 BMS input signals

The systems response to a 0-10V dc BMS signal is given in the following table. Note the BMS signal will override any sensors and user control connected in the system.

The voltage tolerance is +/- 125mV and is measured at the fans terminal.

	Ventilation mode	Cooling mode*	Heating mode*
Local control	0.00	-	-
OFF/trickle	0.25	-	-
Speed 1	0.50	0.75	1.00
Speed 2	1.50	1.75	2.00
Speed 3	2.50	2.75	3.00
Speed 4	3.50	3.75	4.00
Speed 5	4.50	4.75	5.00
Speed 6	5.50	5.75	6.00
Speed 7	6.50	6.75	7.00
Speed 8	7.50	7.75	8.00
Speed 9	8.50	8.75	9.00
Speed 10	9.50	9.75	10.00

* Only available on relevant unit

5.0 Setting the airflow

Setting the maximum air flow

i) Ensure the power supply is switched off and that a link wire is connected from the supply L to the SL terminal. Unplug all items connected to the 'Net' connectors.

ii) Switch on the power supply.

Note: Ensure unit cover is securely attached.

iii) Wait for the fan to complete its self-test operation.

iv) Remove the cover of the units external commissioning box. Measure the airflow using standard commissioning instruments at a suitable point in the ductwork. If adjustment is required, rotate the pot marked 'MAX' to obtain the desired airflow.

Setting the minimum trickle airflow (nominally 40%)

i) Repeat the same procedure as for maximum airflow above but without the link wire between supply L and SL terminal. Ensure the trickle switch is in the 'ON' position. The adjustment must be made on the pot marked 'Min'.

ii) Note that the minimum setting (nominally 40%) must be below the maximum setting, otherwise minimum setting will be automatically set to be the same as the maximum. After setting the airflows, re-connect all the items disconnected previously. Ensure that the cover over the mains terminals is replaced and that the cover of the controls enclosure is securely fastened.

IMPORTANT

Isolation - Before commencing work make sure that the unit, switched live and Nuair control are electrically isolated from the mains supply.

Maintenance Intervals

The first maintenance should be carried out three months after commissioning and thereafter at twelve monthly intervals. These intervals may need to be shortened if the unit is operating in adverse environmental conditions, or in heavily polluted air.

Note: failure to maintain the unit as recommended will invalidate the warranty.

Lubrication

Motors are fitted with sealed for life bearings and do not require any lubrication.

General Cleaning and Inspection

Clean and inspect the exterior of the fan unit and associated controls etc. Remove the access panel from the fan unit. Inspect and, if necessary, clean the fan and motor assemblies and the interior of the case. If the unit is heavily soiled it may be more convenient to remove the fan/motor assemblies. Check that the shutters are free to move smoothly and that they seal the appropriate fan outlet effectively. Clean and inspect each fan and motor assembly as follows; taking care not to damage, distort or disturb the balance of the impeller.

- a) Lightly brush away dirt and dust, paying particular attention to any build up at the motor ventilating slots. If necessary, carefully remove with a blade or scraper.
- b) Stubborn dirt at the impeller may be carefully removed with a stiff nylon brush.
- c) Check all parts for security and general condition. Check that the impeller rotates freely.

Refit the assemblies to the unit (see Replacement of Parts) then replace the access covers.

If Nuair controls and or remote indicators are fitted, remove the covers and carefully clean out the interiors as necessary. Check for damage.

Check security of components. Refit the access covers.

Replacement of Parts

The only item of the fan units unit likely to require replacement are the fan/motor assemblies due to a failed motor or damaged impeller. In either eventuality the complete fan/ motor assembly must be removed from the unit case.

Note: before commencing work, electrically isolate the fan unit and/or the associated Nuair control, if fitted, from the mains supply.

Remove the access cover. Disconnect the incoming wiring from the connection box (located on the fan scroll) on the particular fan/motor assembly to be removed. Support the weight of the fan/motor assembly and remove the mounting screws and washers. Lift the assembly out of the case.

After replacing the faulty item, refit the fan/motor assembly and re-connect the incoming wiring to the fan mounted connection box. Replace the access cover.

Spare Parts

When ordering spares please quote the serial number of the unit together with the part number. If the part number is not known please give a full description of the part required. The serial number will be found on the identification plate attached to the unit casing.

Warranty

Xtractor has a 3 year warranty. Ecosmart Xtractor has a 5 year warranty. The warranty starts from the day of delivery and includes parts and labour for the first year. The remaining period covers replacement parts only.

This warranty is void if the equipment is modified without authorisation, is incorrectly applied, misused, disassembled, or not installed, commissioned and maintained in accordance with the details contained in this manual and general good practice.

The product warranty applies to the UK mainland and in accordance with Clause 14 of our Conditions of Sale. Customers purchasing from outside of the UK should contact Nuair International Sales office for further details.

After Sales Enquiries

For technical assistance or further product information, please contact the After Sales Department.



Telephone 02920 858 400

DECLARATION OF INCORPORATION AND INFORMATION FOR SAFE INSTALLATION, OPERATION AND MAINTENANCE

We declare that the machinery named below is intended to be assembled with other components to constitute a system of machinery. All parts except for moving parts requiring the correct installation of safety guards comply with the essential requirements of the Machinery Directive. The machinery shall not be put into service until the system has been declared to be in conformity with the provisions of the EC Machinery Directive.

Designation of machinery: ESX
Machinery Types: Xtractor Direct Drive Fans
Relevant EC Council Directives: 2006/42/EC (Machinery Directive)
Applied Harmonised Standards: BS EN ISO 12100-1, BS EN ISO 12100-2, EN60204-1, BS EN ISO 9001, BS EN ISO 13857
Applied National Standards: BS5488 Parts 1, 2.2 and 5
 Note: All standards used were current and valid at the date of signature.

Signature of manufacture representatives:

Name:	Position:	Date:
1) C. Biggs 	Technical Director	26. 01. 11
2) A. Jones 	Manufacturing Director	26. 01. 11

INFORMATION FOR SAFE INSTALLATION, OPERATION AND MAINTENANCE OF NUAIRE VENTILATION EQUIPMENT

To comply with EC Council Directives 2006/95/EC Machinery Directive and 2014/30/EU (EMC).

To be read in conjunction with the relevant Product Documentation (see 2.1)

1.0 GENERAL

1.1 The equipment referred to in this Declaration of Incorporation is supplied by Nuaire to be assembled into a ventilation system which may or may not include additional components.
 The entire system must be considered for safety purposes and it is the responsibility of the installer to ensure that all of the equipment is installed in compliance with the manufacturers recommendations and with due regard to current legislation and codes of practice.

2.0 INFORMATION SUPPLIED WITH THE EQUIPMENT

2.1 Each item of equipment is supplied with a set of documentation which provides the information required for the safe installation and maintenance of the equipment. This may be in the form of a Data sheet and/or Installation and Maintenance instruction.
 2.2 Each unit has a rating plate attached to its outer casing. The rating plate provides essential data relating to the equipment such as serial number, unit code and electrical data. Any further data that may be required will be found in the documentation. If any item is unclear or more information is required, contact Nuaire.
 2.3 Where warning labels or notices are attached to the unit the instructions given must be adhered to.

3.0 TRANSPORTATION, HANDLING AND STORAGE

3.1 Care must be taken at all times to prevent damage to the equipment. Note that shock to the unit may result in the balance of the impeller being affected.
 3.2 When handling the equipment, care should be taken with corners and edges and that the weight distribution within the unit is considered. Lifting gear such as slings or ropes must be arranged so as not to bear on the casing.
 3.3 Equipment stored on site prior to installation should be protected from the weather and steps taken to prevent ingress of contaminants.

4.0 OPERATIONAL LIMITS

4.1 It is important that the specified operational limits for the equipment are adhered to e.g. operational air temperature, air borne contaminants and unit orientation.
 4.2 Where installation accessories are supplied with the specified equipment e.g. wall mounting brackets. They are to be used to support the equipment only. Other system components must have separate provision for support.
 4.3 Flanges and connection spigots are provided for the purpose of joining to duct work systems. They must not be used to support the ductwork.

5.0 INSTALLATION REQUIREMENTS

In addition to the particular requirements given for the individual product, the following general requirements should be noted.

5.1 Where access to any part of equipment which moves, or can become electrically live are not prevented by the equipment panels or by fixed installation detail (eg ducting), then guarding to the appropriate standard must be fitted.
 5.2 The electrical installation of the equipment must comply with the requirements of the relevant local electrical safety regulations.
 5.3 For EMC all control and sensor cables should not be placed within 50mm or on the same metal cable tray as 230V switched live, lighting or power cables and any cables not intended for use with this product.

6.0 COMMISSIONING REQUIREMENTS

6.1 General pre-commissioning checks relevant to safe operation consist of the following:
 Ensure that no foreign bodies are present within the fan or casing.
 Check electrical safety. e.g. Insulation and earthing.
 Check guarding of system.
 Check operation of Isolators/Controls.
 Check fastenings for security.
 6.2 Other commissioning requirements are given in the relevant product documentation.

7.0 OPERATIONAL REQUIREMENTS

7.1 Equipment access panels must be in place at all times during operation of the unit, and must be secured with the original fastenings.
 7.2 If failure of the equipment occurs or is suspected then it should be taken out of service until a competent person can effect repair or examination. (Note that certain ranges of equipment are designed to detect and compensate for fan failure).

8.0 MAINTENANCE REQUIREMENTS

8.1 Specific maintenance requirements are given in the relevant product documentation.
 8.2 It is important that the correct tools are used for the various tasks required.
 8.3 If the access panels are to be removed for any reason the electrical supply to the unit must be isolated.
 8.4 A minimum period of two minutes should be allowed after electrical disconnection before access panels are removed. This will allow the impeller to come to rest. **NB: Care should still be taken however since airflow generated at some other point in the system can cause the impeller to "windmill" even when power is not present.**
 8.5 Care should be taken when removing and storing access panels in windy conditions.

Technical or commercial considerations may, from time to time, make it necessary to alter the design, performance and dimensions of equipment and the right is reserved to make such changes without prior notice.

Notes

Notes



Western Industrial Estate
Caerphilly United Kingdom
CF83 INA
T: 029 2088 5911
F: 029 2088 7033
E: info@nuaire.co.uk
W: www.nuaire.co.uk