

IpXboxac

Mechanical Ventilation with Heat Recovery

Installation and Maintenance

1.0 Introduction

The Nuair IpXboxac unit is designed to provide mechanical supply and extract ventilation with heat recovery.

The unit is fitted with two fans with independent adjustable speed control. A plate heat-exchange constructed from aluminium is used to provide up to 70% heat recovery.

Figure 1.

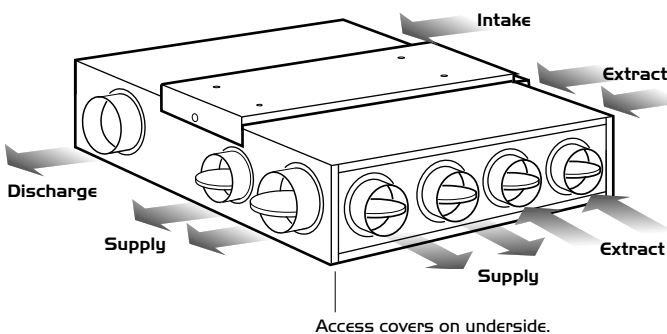

2.0 Installation

Installation must be carried out by competent personnel conforming to all statutory and governing regulations including the current wiring and CDM regulations.

Special attention must be paid to the size and weight of the unit and the handling method to locate the unit in situ.

The unit is designed to be ceiling mounted in the horizontal plane with access panels and condensate drain on the underside.

The fan must be fitted indoors, away from any direct sources of heat, water spray or moisture generation. Temperature range -5°C to 40°C.

Please note a clear working space is required around the installed unit to allow the cover to be removed and provide sufficient access for maintenance such as filter change.

The fan is designed to be wired direct to the mains supply through a fused spur isolator (by others).

With the unit fixed in position and working from underneath the installation bring the mains wiring through the chosen rubber cable entry grommet at the new connection box.

Additional grommeted holes are provided to allow additional wiring to each blower.

Figure 2.

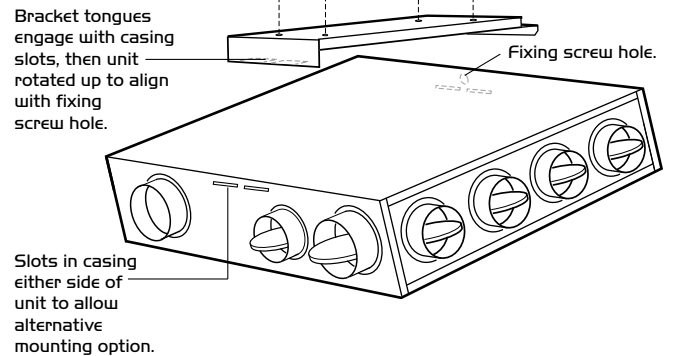

The integral mounting bracket supplied can be offered up to position, the fixing points marked through and the bracket installed with 4 screws (by others).

Offer the unit into position and locate the bracket into the slots in the case before fixing with the single bracket fixing screw.

Figure 3.

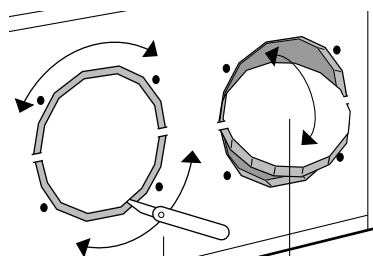

Cut through the acoustic foam round the circumference of the damper.

Damper can be swivelled on the 2 body casing hinges.

Figure 4.

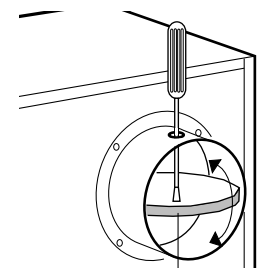

When spigot is in position, damper can be adjusted using a screwdriver.

Various damper/inlet spigot positions can be utilised as required to suit the system ductwork and extract grilles. To reduce air leakage, spigots should be sealed to the unit by silicone sealant or similar (by others).

All inlet dampers are 'closed' as knockouts when delivered but can be opened using a sharp knife. (See figure 3). After the spigot has been fixed adjust the damper with a screwdriver. (See figure 4).

See figure 5 for spigot location and sizes.

The condensate drain must be connected via a trap into either a suitable waste water system or to the outside of the building. This connection must be detachable to allow access into the unit. Ensure the pipe from the condensate drain falls away from the unit.

2.0 Dimensions

Figure 5. Dimensions in mm.

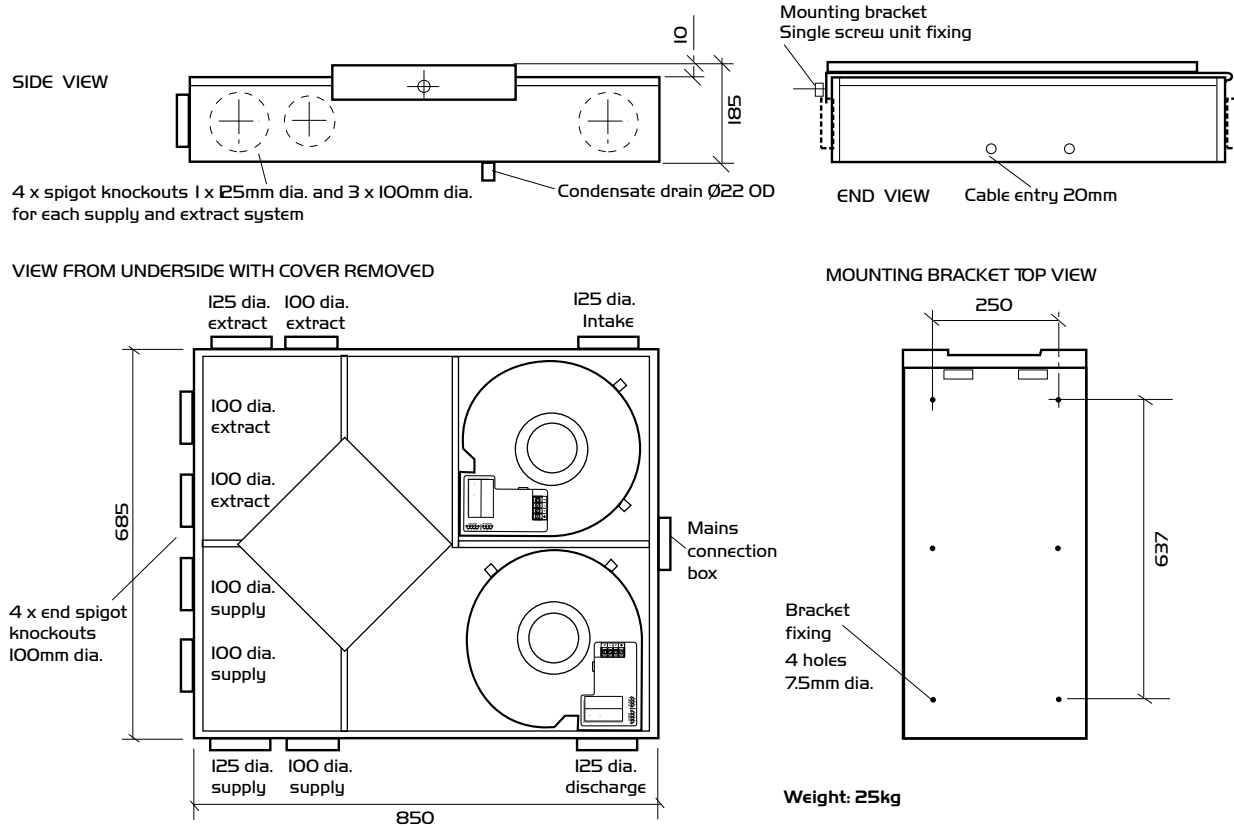

3.0 Electrical Wiring

IMPORTANT

Isolation - Before commencing work make sure that the unit, switched live and Nuair control are electrically isolated from the mains supply. Please note this product must be earthed.

Figure 6.

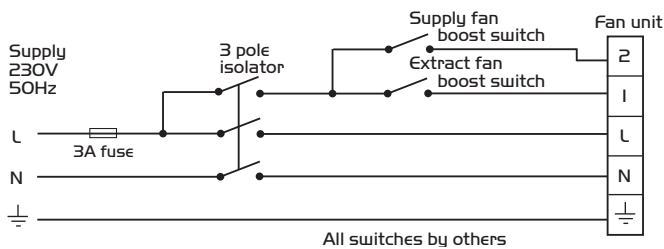

The two fans are pre-wired into an external wiring box for ease of connection. (see figure 6 for connection details). All incoming mains connections must be routed through a suitable local isolator for maintenance purposes.

IMPORTANT

For good EMC engineering practice, any sensor cables or switched live cables should not be placed within 50mm of other cables or on the same metal cable tray as other cables.

3.1 Additional Control Wiring Option

Units are supplied configured to run on speeds 1 and 3. To change the duty the links may be removed and refitted to the other positions. (See table 1).

Figure 7. Circuit Board Connections.

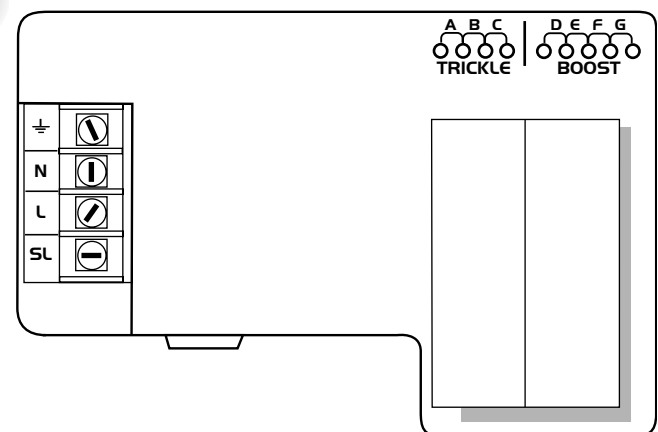

Table 1.

TRICKLE	BOOST
SPEED 1-Link B (As supplied)	SPEED 3-Link D & F (As supplied)
SPEED 2-Link C	SPEED 4-Link G
SPEED 3-Link A & C	SPEED 4-Link G

4.0 Maintenance

It is inevitable that even with filtered extract grilles as recommended in BRE digest 398 some dust, fluff etc. will pass through the filter, and which, if allowed, will build up internally on motors and impellers, shortening the life of the unit and, in severe cases, leading to overheating of the motors. Consequently, it is strongly recommended that all units are inspected and cleaned every six months.

It is recommended that the drip-tray and the heat-exchanger should be inspected, cleaned and disinfected at regular intervals to prevent a build-up of mould and bacterial growth.

5.0 Cleaning

Remove covers and carefully clean out interiors as necessary. To clean the filter, remove from the unit and wash in tepid water to which a little mild detergent has been added. Shake out excess water and allow to dry naturally. Replace when dry. Check for damage and security of components. Refit covers.

To remove the drip-tray and the heat-exchanger, remove the screws securing the retainer clips. Take care not to let the drip-tray and the heat-exchanger drop down. Clean by washing the parts in tepid water with suitable disinfectant. Allow to dry naturally before refitting back into the unit.

6.0 Replacement of Parts

Should any component need replacing Nuaire keep extensive stocks for quick delivery. Ensure that the unit is electrically isolated, before carrying out any work.

When ordering spare parts, please quote the serial number of the unit and the ARC number of the purchase if possible. **(This information will be available on the fan label).**

7.0 Warranty

The 5 year warranty starts from the day of delivery and includes parts and labour for the first year and parts only for the remaining four years. This warranty is conditional on planned maintenance being undertaken.

8.0 Service Enquiries

Nuaire can assist you in all aspects of service. Our service department will be happy to provide any assistance required, initially by telephone and if necessary arrange for an engineer to call.



Telephone 087 0500 2555
Fax 087 0500 2666

DECLARATION OF INCORPORATION AND INFORMATION FOR SAFE INSTALLATION, OPERATION AND MAINTENANCE

We declare that the machinery named below is intended to be assembled with other components to constitute a system of machinery. The machinery shall not be put into service until the system has been declared to be in conformity with the provisions of the EC Machinery Directive.

Designation of machinery: IpXboxac
Machinery Types: Mechanical Ventilation with Heat Recovery Unit
Relevant EC Council Directives: 98/37/EC, 98/79/EC (Machinery Directive)
Applied Harmonised Standards: BS EN ISO 12100-1, BS EN ISO 12100-2, EN294, EN60204-1, BS EN ISO 9001
Applied National Standards: BS848 Parts One, Two and Five

Signature of manufacture representatives:



Name:	Position:	Date:
1) C. Biggs 	Technical Director	20. 07. 07
2) W. Glover 	Manufacturing Director	20. 07. 07

CE DECLARATION OF CONFORMITY

We declare that the machine named below conforms to the requirements of EC Council Directives relating to Electromagnetic Compatibility and Safety of Electrical Equipment.

Designation of machinery: IpXboxac
Machinery Types: Mechanical Ventilation with Heat Recovery Unit
Relevant EC Council Directives: 2004/108/EC (EMC) 2006/95/EC (Low Voltage Directive)
Applied Harmonised Standards: EN55014-1, EN55014-2, EN60335-2-80
Basis of Self Attestation: Quality Assurance to BS EN ISO 9001 BSI Registered Firm Certificate No. FM 149

Signature of manufacture representatives:

Name:	Position:	Date:
1) C. Biggs 	Technical Director	20. 07. 07
2) W. Glover 	Manufacturing Director	20. 07. 07

INFORMATION FOR SAFE INSTALLATION, OPERATION AND MAINTENANCE OF NUAIRE VENTILATION EQUIPMENT

To comply with EC Council Directives 98/37/EC Machinery Directive and 2004/108/EC (EMC).

To be read in conjunction with the relevant Product Documentation (see 2.1)

1.0 GENERAL

- 1.1 The equipment referred to in this Declaration of Incorporation is supplied by Nuairé to be assembled into a ventilation system which may or may not include additional components.
 The entire system must be considered for safety purposes and it is the responsibility of the installer to ensure that all of the equipment is installed in compliance with the manufacturers recommendations and with due regard to current legislation and codes of practice.

2.0 INFORMATION SUPPLIED WITH THE EQUIPMENT

- 2.1 Each item of equipment is supplied with a set of documentation which provides the information required for the safe installation and maintenance of the equipment. This may be in the form of a Data sheet and/or Installation and Maintenance instruction.
- 2.2 Each unit has a rating plate attached to its outer casing. The rating plate provides essential data relating to the equipment such as serial number, unit code and electrical data. Any further data that may be required will be found in the documentation. If any item is unclear or more information is required, contact Nuairé.
- 2.3 Where warning labels or notices are attached to the unit the instructions given must be adhered to.

3.0 TRANSPORTATION, HANDLING AND STORAGE

- 3.1 Care must be taken at all times to prevent damage to the equipment. Note that shock to the unit may result in the balance of the impeller being affected.
- 3.2 When handling the equipment, care should be taken with corners and edges and that the weight distribution within the unit is considered. Lifting gear such as slings or ropes must be arranged so as not to bear on the casing.
- 3.3 Equipment stored on site prior to installation should be protected from the weather and steps taken to prevent ingress of contaminants.

4.0 OPERATIONAL LIMITS

- 4.1 It is important that the specified operational limits for the equipment are adhered to e.g. operational air temperature, air borne contaminants and unit orientation.
- 4.2 Where installation accessories are supplied with the specified equipment eg. wall mounting brackets. They are to be used to support the equipment only. Other system components must have separate provision for support.
- 4.3 Flanges and connection spigots are provided for the purpose of joining to ductwork systems. They must not be used to support the ductwork.

5.0 INSTALLATION REQUIREMENTS

In addition to the particular requirements given for the individual product, the following general requirements should be noted.

- 5.1 Where access to any part of equipment which moves, or can become electrically live are not prevented by the equipment panels or by fixed installation detail (eg ducting), then guarding to the appropriate standard must be fitted.
- 5.2 The electrical installation of the equipment must comply with the requirements of the relevant local electrical safety regulations.
- 5.3 For EMC all control and sensor cables should not be placed within 50mm or on the same metal cable tray as 230V switched live, lighting or power cables and any cables not intended for use with this product.

6.0 COMMISSIONING REQUIREMENTS

- 6.1 General pre-commissioning checks relevant to safe operation consist of the following:
 Ensure that no foreign bodies are present within the fan or casing.
 Check electrical safety. e.g. Insulation and earthing.
 Check guarding of system.
 Check operation of Isolators/Controls.
 Check fastenings for security.
- 6.2 Other commissioning requirements are given in the relevant product documentation.

7.0 OPERATIONAL REQUIREMENTS

- 7.1 Equipment access panels must be in place at all times during operation of the unit, and must be secured with the original fastenings.
- 7.2 If failure of the equipment occurs or is suspected then it should be taken out of service until a competent person can effect repair or examination. (Note that certain ranges of equipment are designed to detect and compensate for fan failure).

8.0 MAINTENANCE REQUIREMENTS

- 8.1 Specific maintenance requirements are given in the relevant product documentation.
- 8.2 It is important that the correct tools are used for the various tasks required.
- 8.3 If the access panels are to be removed for any reason the electrical supply to the unit must be isolated.
- 8.4 A minimum period of two minutes should be allowed after electrical disconnection before access panels are removed. This will allow the impeller to come to rest.
NB: Care should still be taken however since airflow generated at some other point in the system can cause the impeller to "windmill" even when power is not present.
- 8.5 Care should be taken when removing and storing access panels in windy conditions.