

XBOXER

Run Around Coil

Installation, Operating and Maintenance Instructions

This document refers to the following Nuaire Run Around Coil products:

Code description example

R4NC - RAC - L 2 WP

1 2 3 4 5 6

- 1. = Type/Curve Ref.
- 2. = Ecosmart control as standard
NC = No control
- 3. = Run around coil
- 4. = Unit type
L = LPHW
N = No heater
- 5. = 2 row coil or 3 = 3 row coil
- 6. = Optional Weather Roof

Please note - project specific variations of these products may be supplied.

Such products will be identified on the unit rating plate by the reference - Qaxxxx.

Generally, the standard product information given here will apply, and any additional information necessary for the safe installation, operation and maintenance of the product will be supplied directly to the contractor.

AHU with Heat Recovery section and direct drive AC motor technology.

Unit overall dimensions (mm)

Unit Code	A	B	C	Duct size D x E
R4-RAC-L/N/NC	2800	1600	1600	1540 x 740
R5-RAC-L/N/NC	3200	2000	2000	1940 x 940
R6-RAC-L/N/NC	3800	2600	2600	2540 x 1240

N.B If CW or DX modules are included add 600mm to overall length.

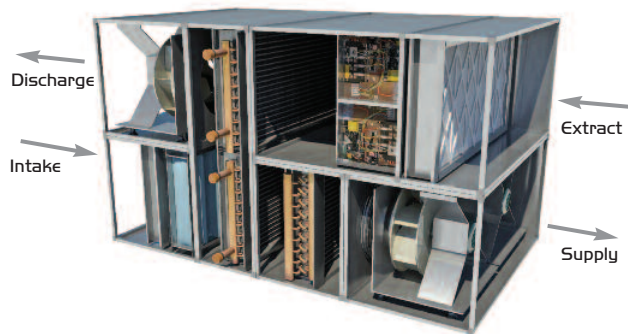
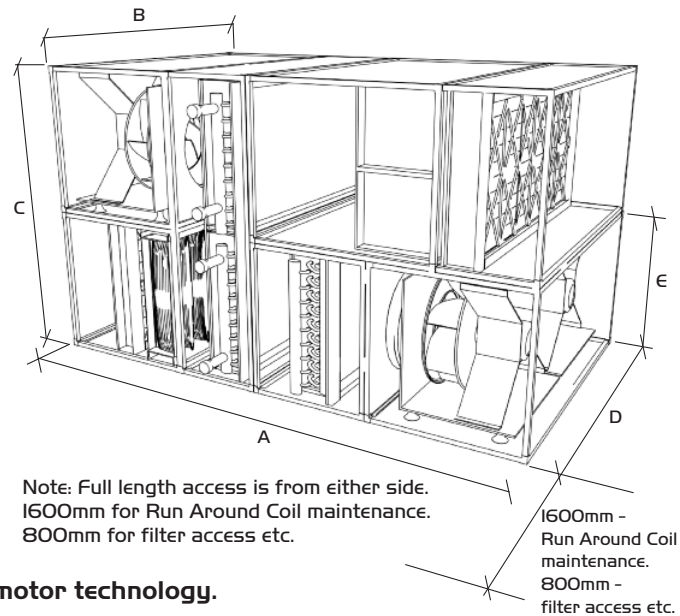

Figure 1. Model shown: R4/6-RAC-L (LPHW). Includes Ecosmart control.

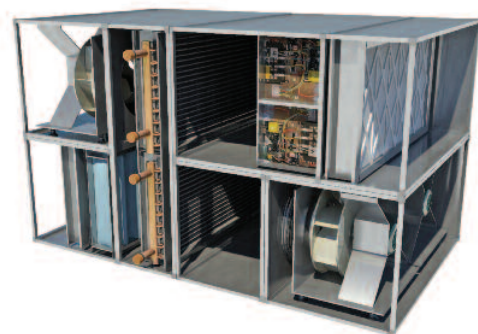

Figure 2. Model shown: R4/6-RAC-N (No heater). Includes Ecosmart control.

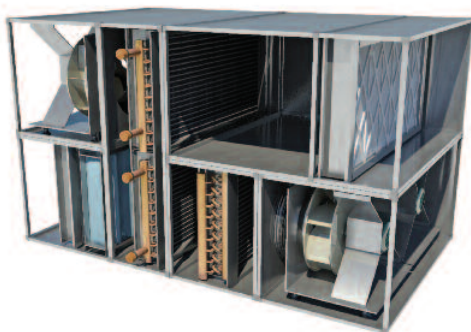

Figure 3. Model shown: R4/6NC-RAC-L (LPHW). No Ecosmart control.

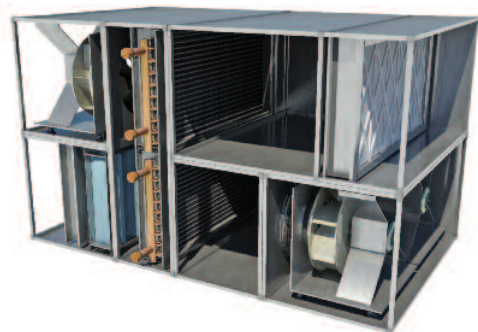

Figure 4. Model shown: R4/6NC-RAC-N (No heater). No Ecosmart control.

1.0 General

IMPORTANT

Safety first! –before commencing any work ensure:

- That all appropriate risk assessments have been carried out, and the required safety measures have been taken
- That you understand the work required
- That you are trained and competent to carry it out

The information contained in this document gives details of operation and maintenance for installers and users of Nuair XBOXER Run around coil equipment.

These air handling units comprise a combination of modular sections assembled (at works or on site) to suit the application requirements as specified by the purchaser.

General information regarding performance and specifications for the equipment may be obtained from our Technical Literature, and / or project specific documentation.

2.0 Delivery of Equipment

2.1 Receipt of equipment

All equipment is inspected prior to despatch and leaves the factory in good condition. Upon receipt of the equipment an inspection should be made and any damage indicated on the delivery note.

Particulars of damage and/or incomplete delivery should be endorsed by the driver delivering the goods before offloading by the purchaser.

No responsibility will be accepted for damage sustained during the offloading from the vehicle or on the site thereafter.

All claims for damage and/or incomplete delivery must be reported to Nuair within two days of receipt of the equipment.

2.2 Offloading and Handling from the delivery Vehicle

The units will be delivered in 3 sections (see 3.2). The weight of the unit sections and palletised items is displayed on the unit rating plate or on the packaging. Some of the sections have an uneven weight distribution, and this will be indicated by labelling where appropriate. Ensure that lifting and handling equipment is adequately rated.

Offloading and positioning of the equipment is the responsibility of the purchaser.

Spreaders should be used when lifting with slings to avoid damage to the casings. Care must be taken to ensure that slings are correctly positioned to avoid crushing and twisting of the unit castings.

Where channels and/or support frames are bolted to the underside of the unit casing, slings or fork-lift arms should be positioned to locate in the apertures in the channels. If Lifting Eyes have been supplied / fitted it is recommended that they are used.

Figure 5. Lifting

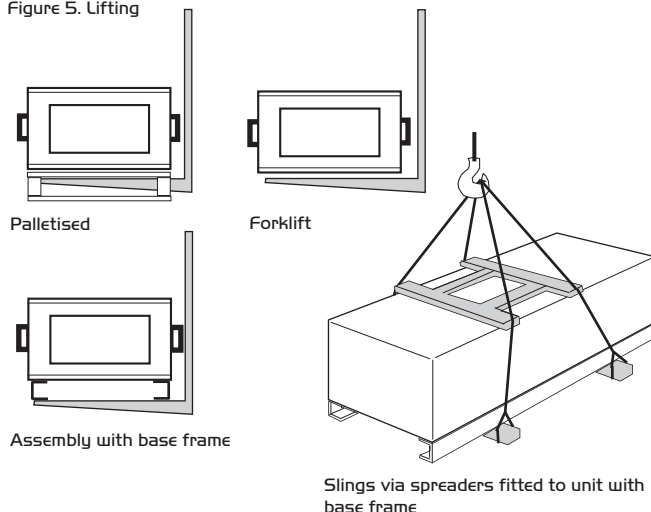

2.3 Storage

The equipment must be stored in a dry, internal location. Ductwork connection apertures shall be sealed against the ingress of dust, water and vermin.

Note that units that are intended for external locations are generally not fully weatherproof until their installation, including ductwork connections is complete.

If the storage period is to exceed two months, contact Nuair for guidance on the appropriate “mothballing” procedures.

Do not stack units, modules or components.

3.0 Erection and Assembly

Units must be installed in accordance with good industry practice, upright and level on a prepared base (which may include a suitably designed suspended platform).

Support positions should be determined to provide a distributed support for the unit base, and should not obstruct access panels or air way connections.

Heat recovery modules and modules that incorporate cooling coils may produce condensation during use. An insulated drip tray and drain connection is provided, and should be connected to a suitable drainage point. (***Note that provision of a powered condensate pump is an option for this type of equipment. If such a pump is supplied, the main drip tray drainage point should be capped, and the pump discharge tube routed as required. Specific instructions for the pump type fitted will be attached to the unit.**)

Provision may be required, and if so, should be made, for the fitting of a correctly sized cleanable trap to each drain connection.

Figure 6. Drainage point

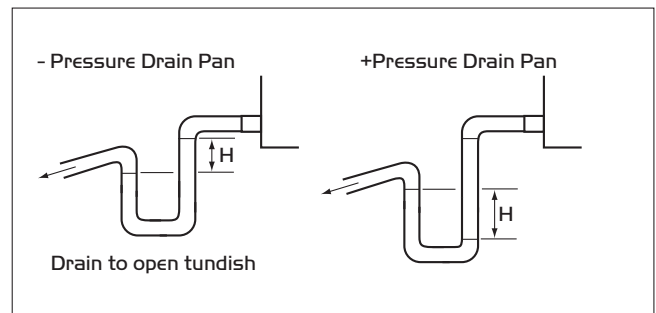

$$H \text{ (mm)} = (\text{Static Pressure (Pa)} / 10) + 12$$

The installation, including all external services and controls should be installed in accordance with the appropriate authority and MUST conform to all governing regulations e.g. CDM,CIBSE, IEE, and in strict accordance with the applicable Building Regulations.

3.1 Equipment Access

Access for maintenance and inspection of the XBOXER units is generally from the sides of the unit.

Once assembled and in position, sufficient free space must be available adjacent to the unit for future inspection, maintenance, component service, repair and replacement and connection of services.

It is recommended that at least the unit width (vertically arranged units XBV) be allowed. Guidance may be found in Approved Document F 2006.

3.2 Assembly of Equipment

SQURBO XBOX unit sections will be delivered to site in 3 sections shown below.

The sections consist of:

1. Extract Fan section,
2. Run Around Coil section,
3. Supply Fan section (includes heater if specified).

Each Section will be labelled with the direction of air flow. The direction convention must be observed during assembly. The units may only be operated in their intended installation plane.

Figure 7. Unit sections shown without weatherproof roof.

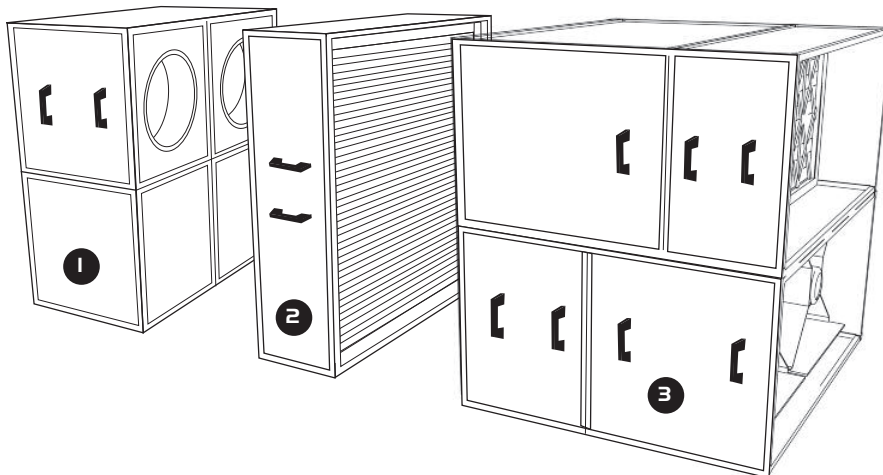

Sectional units are supplied with matching internal connection plates with a single bolt hole provided to each corner through which the sections are bolted together. Unit access panels must be removed to perform the assembly operation plates will either have clearance holes - or one face with a threaded insert and the other with a clearance hole.

A sealing gasket should be applied as necessary to the mating faces of the unit frames before bolting together.

Figure 8. Section assembly plate.

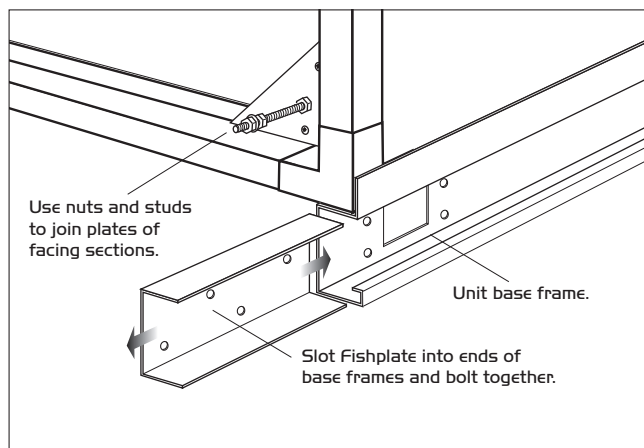

Weatherproof units (see figure 9) in multiple sections will have sectional roof components that must be fitted and sealed after the unit sections are bolted together.

All necessary self drilling screws and sealant are supplied with each unit and are normally bagged and located within the fan section.

The equipment must not be exposed to the weather in an un-assembled or partially assembled state.

All ductwork, sealing and assembly work must be completed before the unit can be considered weather-proof.

Pipe-work connections to heating and / or cooling coils shall be made to the appropriate standard, and the entire circuit tested for tightness. Care must be taken not to over-tighten and distort connections to coils.

LPHW Heating Coil Flow and Return Connection size (Standard Coil)

R4-RAC 2 row as standard	= 54mm
R5-RAC 3 row as standard	= 67mm
R5-RAC 2 row as standard	= 67mm

Connection sizes for other coil types are project specific.

Coils are tested during manufacture to 16 Bar (using dry compressed air). Operation of standard equipment is rated at PNG, if the intended system requires higher operating pressures; please contact the Nuaire Technical department for advice.

Electrical connections to the unit shall be made in accordance with the appropriate product (see below); and installation wiring diagrams, and shall use appropriately sized and rated cables.

The unit rating label shows the maximum electrical load of the equipment.

Connections to the unit may include three phase and single phase supply connections, and a variety of control circuits.

Control circuit connections must be segregated (i.e. routed separately) from power connections.

Only the prepared apertures in the unit casing may be used for cable entry. Do not drill or cut the unit casing for this purpose.

The equipment must be earthed and earth-bonded.

Means of local isolation for maintenance purposes are generally required.

IMPORTANT

Isolation - Before commencing work make sure that the unit and Nuaire control are electrically isolated from the mains supply.

Figure 9. Installed weatherproof roof components.

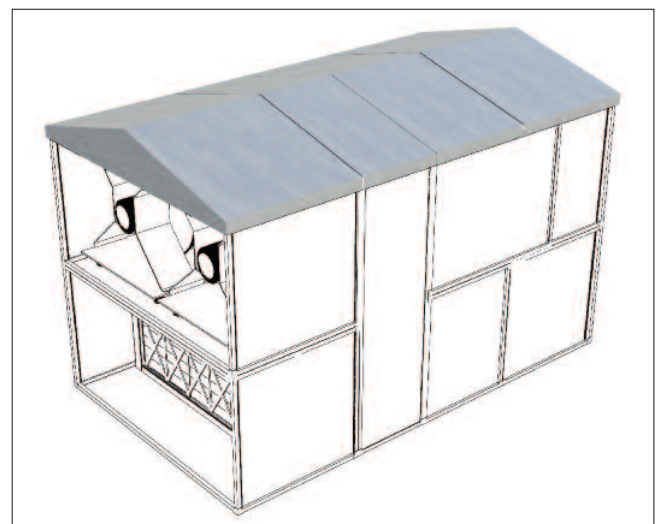

4.0 Wiring

Wiring for units without Ecosmart Control R4, 5, and 6NC RAC

Three Phase Figure 10.

3 phase for DOL STARTING (4kW and above)

3 phase for connection to a STAR /DELTA STARTER (4kW and above)

Note:
For all D.O.L. (Direct On Line) operation or Inverter type Speed Control wire in DELTA 

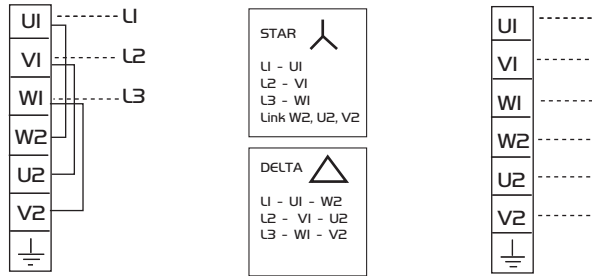

400V 3 phase 50Hz supply

400V 3 phase 50Hz supply

*** Matched Frequency Inverter**

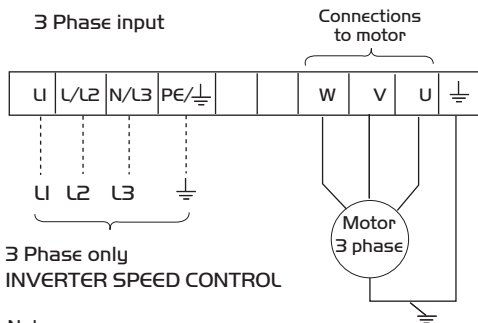

Notes:
Total length of motor leads should not exceed 50 metres. If a screened motor cable is used, maximum length should be 25 metres. Consult our Technical Department if you wish to use longer leads.
Inverters are configured to suit specific fans and control applications as described on the Customer Order free of charge.

400V 3 phase 50Hz supply

* Note: by special order. Refers only to Inverters supplied by Nuair.

Wiring for units with Ecosmart Control R4, 5, and 6-RAC 'N' (No heater) Extract Figure 11.

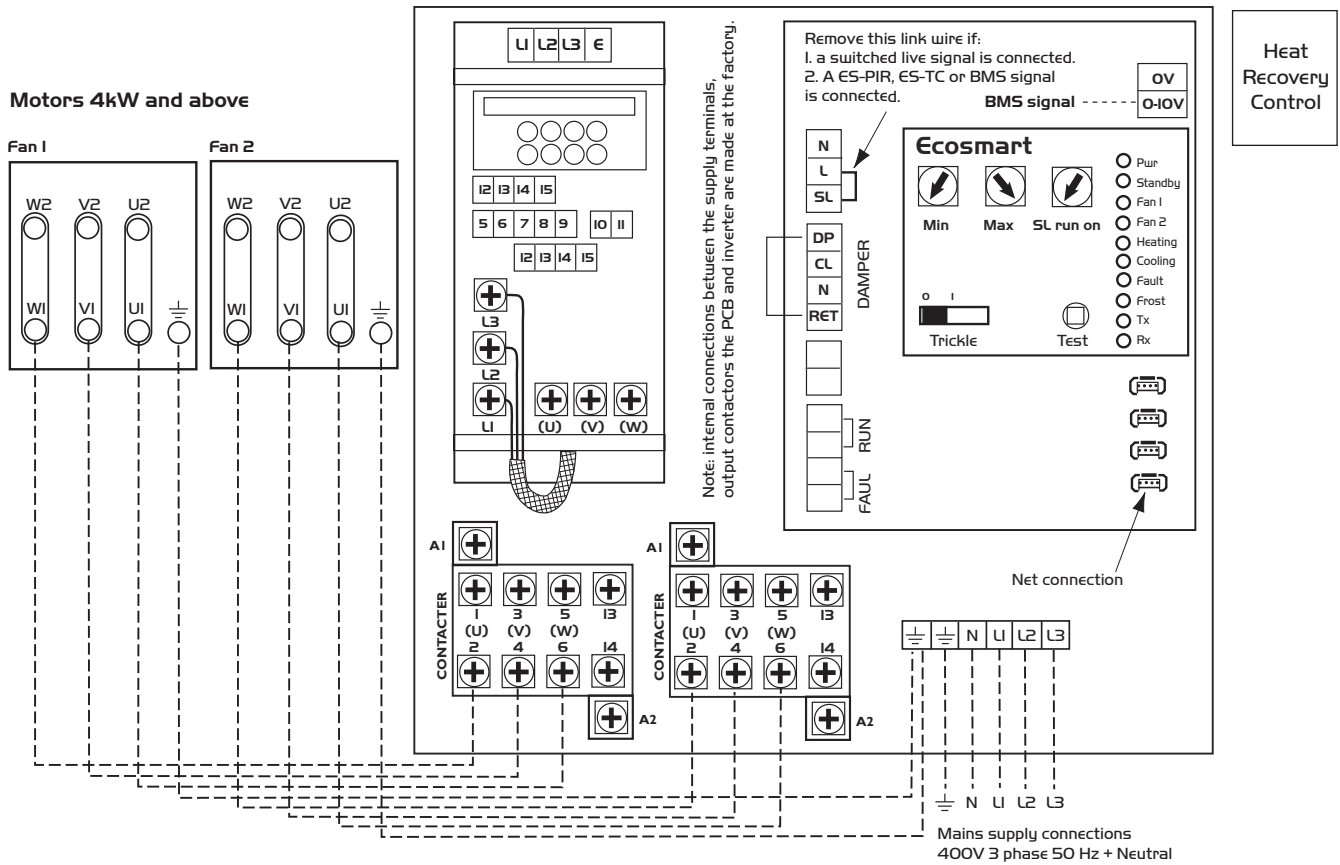

Wiring for units with Ecosmart Control R4, 5, and 6-RAC 'N' (No heater) Supply Figure 12.

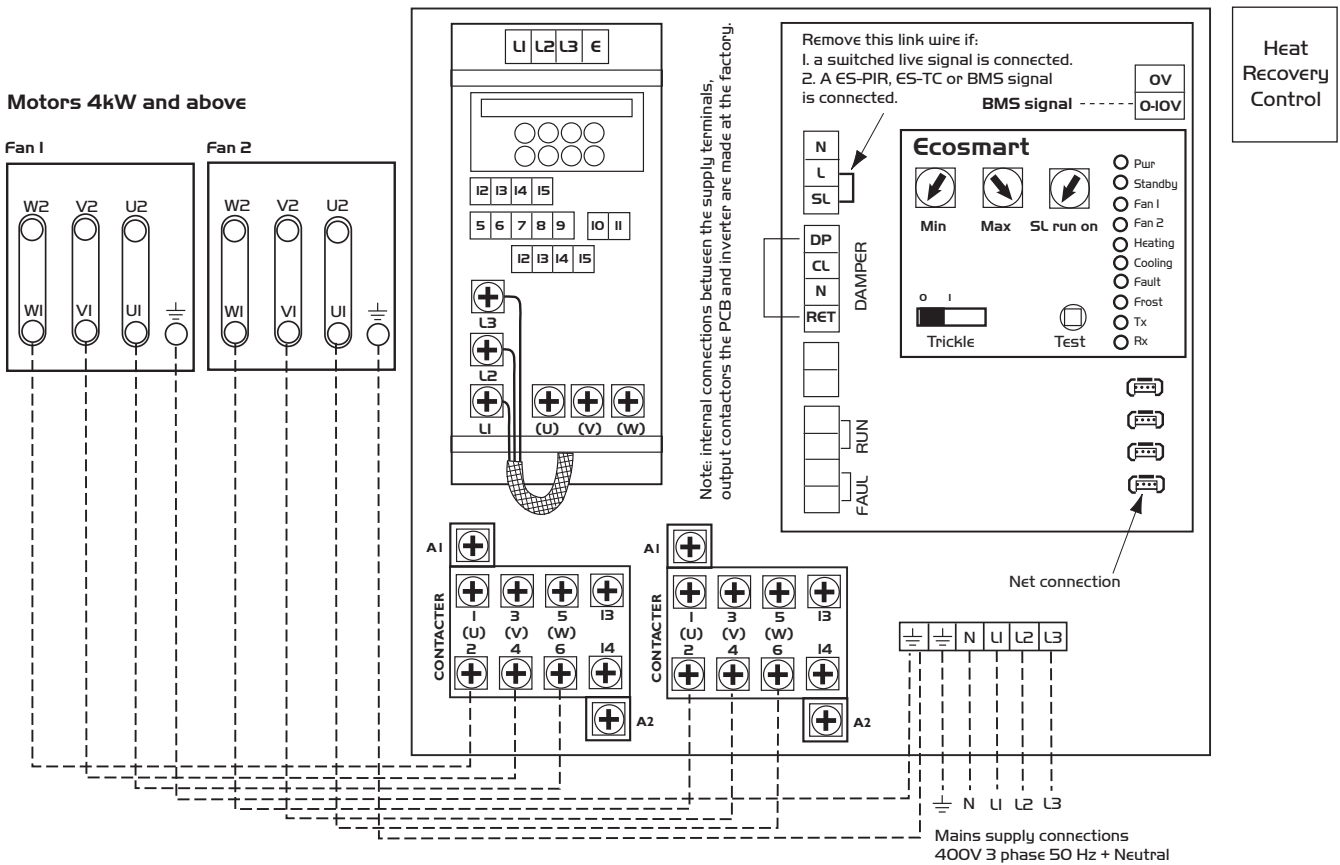

Wiring for units with Ecosmart Control R4, 5, and 6-RAC 'U' (LPHW) Extract Figure 13.

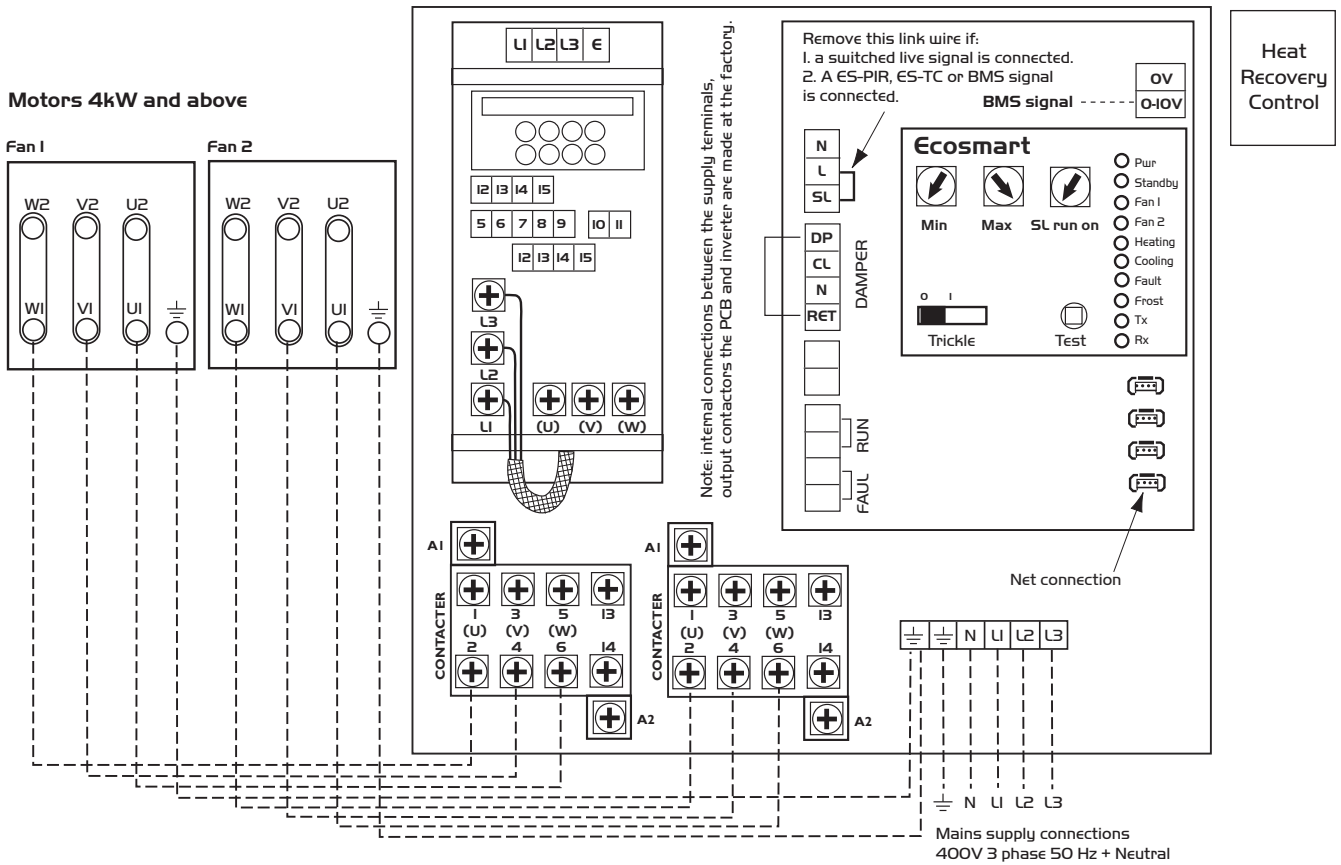

Wiring for units with Ecosmart Control R4, 5, and 6-RAC 'U' (LPHW) Supply Figure 14.

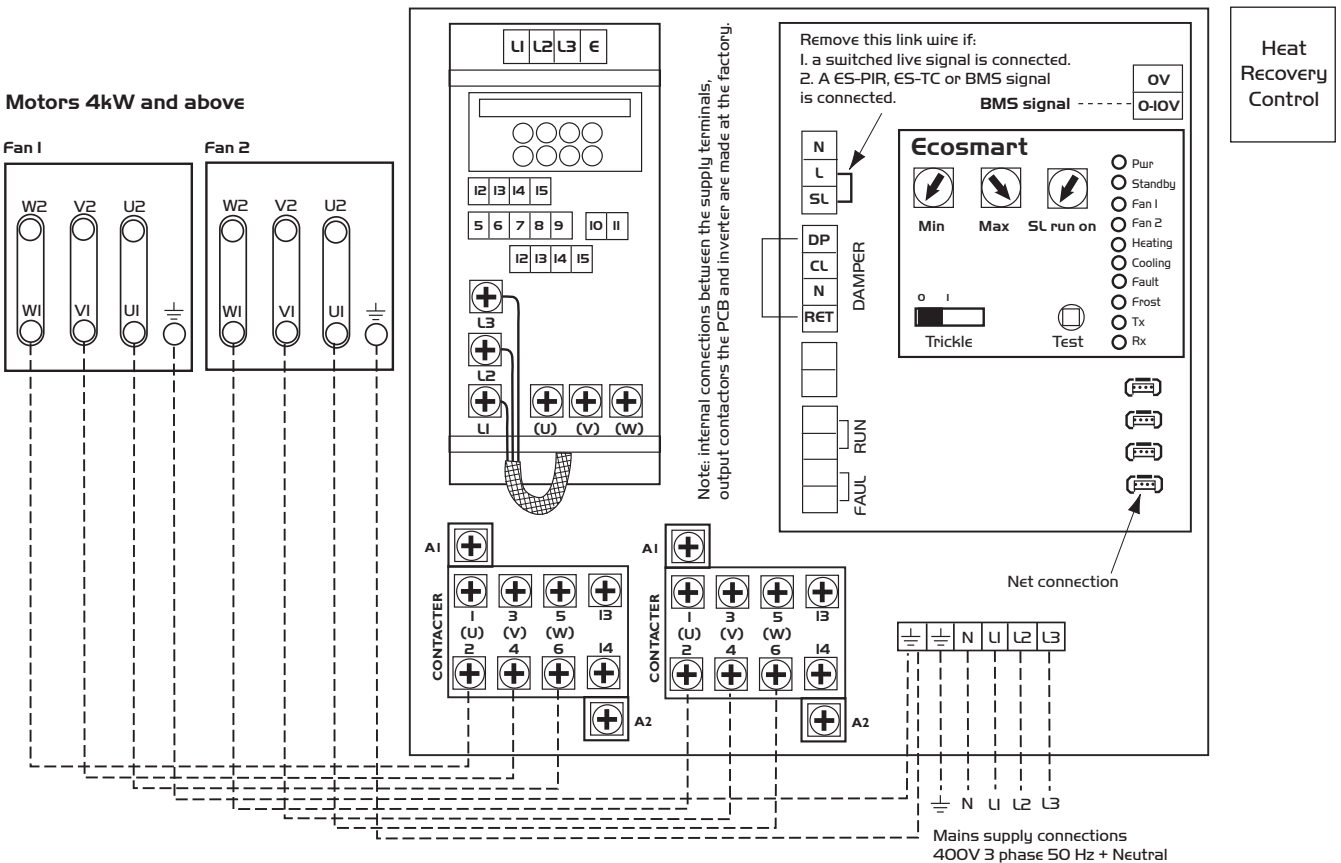

Wiring (continued)

The electrical wiring must be carried out by a competent person and the unit must be provided with means of local isolation (by others) for maintenance purposes.
A suitable isolator is available from Nuair as a separate option.

Connections

a) Mains connections

Mains cables should be suitably sized and terminated at terminals shown on the appropriate diagram.

IMPORTANT

Where units form part of a larger system it will be necessary to install and connect mains wiring between controls and devices such as heat exchangers and motorised dampers - refer to the relevant section of this document.
Where units are supplied in modular sections it will also be necessary to install and connect mains wiring between sensors and actuators and the main control location.

b) Control connections

The facilities described below are provided, but may not be relevant to your installation – refer to project documentation.

Figure 15.
'Net' connection for Ecosmart devices.

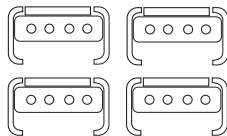

Net - the 4 IDC plug-in connectors are provided for the connection of compatible sensors, manual controls and for linking the fans together under a common control. If more than 4 connections are required, the junction box (product code ES-JB) should be used (see data cable installation).

IMPORTANT

Where units are supplied in modular sections, sizes 6 to 10 it will also be necessary to install data cable (supplied) between Ecosmart controls and from Ecosmart sensors and heat exchanger etc. Some ancillary items (e.g. motorized dampers, Frost Coils) may also require mains rated and data cable connections.

c) Switched Live (SL) terminal

Figure 16.

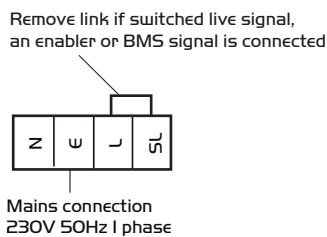

A signal of 100 - 230V a.c. will activate the fan from either its off state or trickle state (see setting to work-trickle switch).
When the SL is disconnected the fan will over-run (see setting to work-timer adjustment).

Do not take this signal from an isolating transformer.

d) Damper connections

Figure 17a. Drive open/
Spring close.

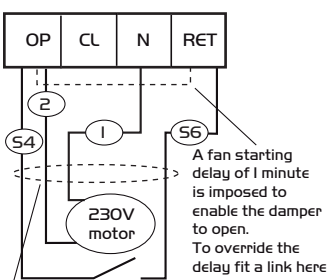

All wiring is IPh 230V 50Hz

Figure 17b. Drive open/
Drive close.

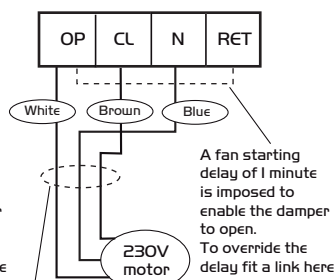

All wiring is IPh 230V 50Hz

- OP** - 230V 50Hz IA max supply to open the damper
- CL** - 230V 50Hz IA max supply to close the damper
- N** - Neutral supply to damper
- RET** - 230V ac return signal from the damper limit switch indicates the damper has reached its operating position. If the return signal is not present, the fan will wait for 1 minute before starting.

Note: If a damper is not fitted, connect a link wire from OP to RET. This will cancel the delay.

e) Volt Free Relay Contacts

Figure 18.

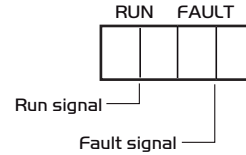

Note that the volt free contacts are not fused. If these are used to power any external equipment, the installer must provide adequate fusing or other protection.

These contacts are rated at 5A resistive, 0.5A inductive.

Run connections - These contacts are closed when the fan is running.

Fault connections - No fault = the contacts are closed.
Fault = the contacts are opened.

Heat demand - contacts closed when heating is selected.

Cooling demand - contacts close when cooling selected.

Do not use this contact to switch compressors directly.

Frost alarm - contacts close when air off temperature is 4°C or below. Fan shuts down, valve opens and the heat demand contacts activated.

DX1 - contacts close when stage 1 of DX coil selected.

DX2 - contacts close when stage 2 of DX coil selected.

Figure 19.

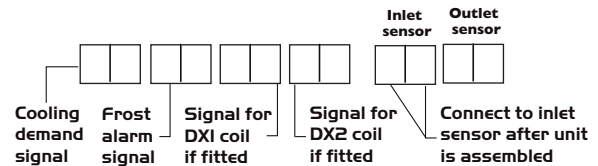

f) Data cable installation

A 4-core SELV data cable is used to connect devices. Do not run data cable in the same conduit as the mains cables and ensure there is a 50mm separation between the data cable and other cables. The maximum cable run between any two devices is 300m when it is installed in accordance with the instructions. **Please note that the total data cable length used in any system must be less than 1000m. Keep the number of cable joints to a minimum to ensure the best data transmission efficiency between devices.**

g) Maximum number of devices

The maximum number of devices (including fans) that can be connected together via the cable is 32, irrespective of their functions.

h) Other low voltage cables

Keep the cable run as short as possible, less than 50 metres.

j) BMS input signals

The BMS connection is made with a plug-in connector via the socket (See figure 20). To ensure the connection is made only by suitably qualified and authorised personnel the plug is not supplied.

It is available from R S Components, Part No. 403-875 or Farnell, Part No. 963-021.

IMPORTANT

Reversal of the BMS connection will damage the control.

Wiring (continued)

Figure 20.

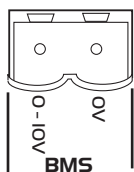

The system's response to a 0-10V dc BMS signal is given in the table below.

Note the BMS signal will override any sensors and user control connected in the system. The voltage tolerance is +/- 125mV and is measured at the fan's terminal.

	Ventilation mode	Cooling mode*	Heating mode*
Local control	0.00	-	-
OFF / trickle	0.25	-	-
Speed 1	0.50	0.75	1.00
Speed 2	1.50	1.75	2.00
Speed 3	2.50	2.75	3.00
Speed 4	3.50	3.75	4.00
Speed 5	4.50	4.75	5.00
Speed 6	5.50	5.75	6.00
Speed 7	6.50	6.75	7.00
Speed 8	7.50	7.75	8.00
Speed 9	8.50	8.75	9.00
Speed 10	9.50	9.75	10.00

* Only available on relevant unit.

5.0 Commissioning & Setting to work

(Note – not all of the components listed here are necessarily included with the equipment supplied).

5.1 Dampers (shut-off, isolation and face/bypass)

Check the free action of the damper blades before powered operation (the actuator has a gear release button). Check that the actuator operates freely and over the correct range.

5.2 Mixing Boxes

Mixing box dampers should be checked as in 4.1 and should be adjusted / set up to give the required airflows through each leg.

5.3 Filters

Remove filter access panels (observe and note airflow direction labels), inspect filters for contamination with construction debris, replace as necessary. Replace access panels.

Filter pressure drops will depend on actual flow rate and condition. Observe and record filter pressure drops after performance commissioning.

Typically, filter “dirty” condition occurs when the initial filter “clean” readings have been increased by 125Pa.

If filter manometers, pressure switches or indicators have been fitted, they should be set or adjusted to reflect the commissioned system operation.

5.4 Heating & Cooling Coils Water

Water coils should be connected to ensure that full counter flow exists i.e. - the entering airflow meets the return connection. All water coils should be connected with the flow at the bottom and the return at the top unless otherwise advised.

Drain and bleed valves are located on the coil, others may be required in the system pipe-work depending on the installation.

Frost protection must be incorporated on shut down and fresh air conditions to avoid coil freezing. The Ecosmart control system if fitted, includes temperature sensing and frost protection strategies. Ideally, where the system is at risk of frost damage, the addition of a proprietary anti-freeze solution to the water is recommended.

Where Ecosmart heating / cooling controls are provided, the coil is pre-fitted with a 3 / 4 port valve and actuator housed in the casing extension.

Pipe-work connections should be made to the unit using appropriate techniques, and must be independently supported. The connections should be pressure tested.

DX

Direct expansion coils must be fitted with a correctly sized thermostatic expansion valve with an external equalising connection. The expansion valve phial must be fitted between the suction header connection and the equalising line. The recommendations of the TE valve manufacturer should be referred to when locating the phial and adjusting the superheat. In all cases, settings should be in accordance with the recommendations of the manufacturer of the refrigeration equipment.

All cooling coil drains must be connected to the sloping drain with a correctly sized trap running to an open tundish or similar.

Note: ES-TC must be used in conjunction with DX.

5.5 Electric Heaters

Remove control access panel to permit site wiring to the Ecosmart heating controller, or directly to the heating elements.

Elements have threaded connection points for linking elements and site wiring. Elements should be linked with reference to the appropriate wiring diagram, and the maximum available element power combination may be decreased if required. Always maintain a balanced load on three phase systems.

Cable entry must be made through the apertures provided. Screwed glands with cable restraint devices should be used.

PVC or similar cables must not be used inside the heater unit – due to the temperatures that may be experienced.

Units with Ecosmart electric heating controls incorporate a fan run-on facility and overheat / fan failure protection.

In non-Ecosmart units, heaters are fitted with an over-heat cut-out that must be wired into the control system.

It is strongly recommended that an airflow switch is incorporated within the control system with a fan run on timer (15 minutes) and an interlock provided between the heater contactor and fan motor starter – to allow elements to cool on shutdown.

Nuaire will accept no liability for damage caused by an inadequate control system.

All heaters must be wired in accordance with IEE regulations and conform to local and national statutory requirements. **The element tray is a mains carrying component and must be earthed.**

5.6 Fan Sections

Access to the fan section is via lift off panels. Cable entry must be made through the apertures provided. Screwed glands with cable restraint devices should be used.

For units with Ecosmart controls, the fan motors and failure protection devices are pre-wired to the control assembly.

For non-Ecosmart units, wiring to the fan motor / unit terminal box should be mechanically protected and in made in accordance with the details on the motor name plate and diagram attached to the unit.

For star delta starting, all links should be removed from the motor terminal box and the motor wired as per the instructions supplied with starter.

With the unit electrically isolated, rotate the fan impeller / drive manually, checking that it spins freely. Check all fixings are secure.

Units must not be operated without all access panels in place – damage to equipment or injury to personnel may result.

Units must not be operated unless control interlocks are in place – damage to equipment may result. Test run motor for condition and correct rotation.

Check that the correct current overloads are fitted and that the current being drawn does not exceed the motor nameplate value. Excessive current normally indicates that the ductwork system resistance is different to design.

5.7 Electrical – Ecosmart Units

Commissioning panel - Using the Test button

The panel is located within the control enclosure – one for each fan.

The test button allows the fan within the unit to be checked for correct operation. If the fan is running already, press the button once to stop the fan, press again to switch on the fan.

Note that the fan will return to normal operation after 30 seconds.

Figure 21.

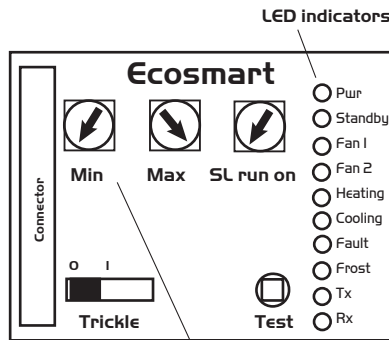

- MIN = Minimum speed adjustment
- MAX = Maximum speed adjustment
- SL = Switched Live Run-On Timer adjustment
- Run on = Switched Live Run-On Timer adjustment
- TRICKLE = Selects trickle running:
0 = off, I = selected
- TEST = Test button

LED Indication

PWR GREEN: Power on & OK,

Standby LED on when fan is not running.

Fan 1 GREEN: Fan 1 is running, **RED:** Fan 1 faulty.

Fan 2 GREEN: Fan 2 is running, **RED:** Fan 2 faulty.

Heating* GREEN: Heating selected

Cooling* GREEN: Cooling selected

Fault: LED on when a fault is present on unit.

Frost* RED: Frost condition exists

Tx LED on when the controller is transmitting data.

Rx LED on when the controller is receiving data.

* Note that this control panel is common to all the Nuair Ecosmart products and may have indicators for functions that are not available in individual units – however, the unused indicators will not be illuminated.

5.8 Settings

Setting the maximum air flow

i) Ensure the power supply is switched off and that a linkwire is connected from the supply L to the SL terminal. Unplug all items connected to the 'Net' connectors.

ii) Switch on the power supply.

iii) Wait for the fan to complete its self-test operation.

Measure the airflow using standard commissioning instruments at a suitable point in the ductwork.

If adjustment is required, rotate the pot marked 'MAX' to obtain the desired airflow. Remove the link wire if not required.

Setting the minimum/trickle airflow rate

(Nominally 40% for S6 units and 20% for all others as standard).

i) Repeat the same procedure as for maximum airflow above but without the link wire between supply L and SL terminal.

Ensure the trickle switch is in the 'ON' position. Adjustment must be made on the pot marked 'Min'.

ii) Note that the minimum setting (nominally 40%) must be below the maximum setting, otherwise the minimum setting will be automatically set to be the same as the maximum.

iii) The minimum speed set is the trickle speed at which the fan operates.

Note: The working adjustment of the fan speed by user control and sensors, ranges between the minimum and maximum set points.

Note :- Where third party controls are specified and fitted, reference should be made to the control specification and operating instructions.

It is the installer's responsibility to ensure that such controls are suitable for operation with the Nuair equipment.

Nuair will accept no liability for equipment damage resulting from incompatible controls.

Mechanical

i) Wet systems require the setting of the coil bypass balancing valve, set using general commissioning procedures - refer to the specified design flow duties and any documentation attached to the valve.

6.0 Maintenance

It is recommended that PPE is always used during the maintenance of Air Handling Equipment – gloves, eye shields and respiratory mask.

IMPORTANT

Isolation - Before commencing work make sure that the unit and Nuair control are electrically isolated from the mains supply.

Warning - Inverter Speed Control

An inverter is used to provide speed control. When the fan is isolated, allow 5 minutes for the capacitors in the inverter to discharge before commencing any work on the unit.

In some Ecosmart units and in some third party controls, variable speed drives (inverters) are used to provide fan speed control. After the fan is isolated, allow at least 5 minutes for the capacitors in the inverter to discharge before commencing any work on the unit.

6.1 Dampers

At regular intervals check that the blades move freely.

6.2 Filters

Disposable filters should be changed when fully dust laden. Washable filters should be removed when fully dust laden and washed in mild detergent solution and washed in mild detergent, flushed with clean water and allowed to dry before replacing.

Carbon filters should be replaced once carbon activation is exhausted.

Inclined gauge manometers, where fitted, should be checked for fluid level.

6.3 Heating and Cooling Coils

Coils should have their finned surface examined for accumulation of dirt, lint and biological contaminants or similar. If necessary, wash down affected areas with a mild detergent solution and a soft brush. Care should be taken not to damage the finned surface, and any cleaning fluids should be rinsed away with water. A compressed air line may be used to blow out any solids between fins. Do not probe the coil fin block with metal objects as damage may cause leaks.

Drain lines should be checked to ensure that they are unobstructed and free draining. Traps should be checked that they are fully primed and functioning.

Drain pans should be flushed out periodically to remove contamination.

Note: The unit application may require particular attention to this item – Check with Building Management personnel for details.

6.4 Electric Heaters

Electric heaters should be checked at regular intervals for condition of elements, wiring and insulation.

6.5 Recuperator

The recuperator block is normally protected from dust and contamination by upstream pre-filters. It is possible to clean the unit with compressed air in the case of dust deposits or by spraying with a mild detergent solution for grease deposits. Solvents, strong alkaline, acidic or any products that may be aggressive to aluminium should not be used. Do not use cleaning water over 50 deg C.

Drain lines should be checked to ensure that they are unobstructed and free draining. Traps should be checked that they are fully primed and functioning.

Drain pans should be flushed out periodically to remove contamination, and chemical treatments may be used to provide protection between service visits.

Note: The unit application may require particular attention to this item – Check with Building Management personnel for details.

6.6 Maintenance and Cleaning of Rotating Heat Exchangers

Maintenance of the rotor

To secure the function and performance, the face of the rotor has to be inspected regularly for dust and dirt. Any dirt or/and dust should be removed. For a small amount of easily removable dirt we recommend to use a vacuum cleaner. For heavier deposits it is possible to use compressed air, with caution. Finally, firm dirt in the rotor can be removed by using hot water and a mild detergent.

Maintenance of drive unit

Tension of the V-belt must be checked after the first 100 hours of operation to secure the rotational function of the wheel.

To adjust tension, first check the belt tensioner and adjust it as much as possible. Secondly, shortening of the V-belt may be required. The V-belt is joined together by an easily removable mechanical lock. Ensure adjustment of the belt tensioner after this operation.

The round belt is self tensioned and no adjustment should be needed.

Maintenance of brush sealants

Tightness between brush sealants and casing has to be checked during inspection. The brush sealants are easily adjusted by loosening the screws and moving the brush sealant into the right position.

V-belt, Round belt and brush sealants are all available as spare parts.

Checking drive belt tension

To check the correct tension of a drive belt, apply a force at right angles to the centre of the belt span sufficient to deflect the belt 16mm for every metre of span length.

The force required to deflect the 'V' belt should be from 0.5kg to 0.8kg.

Figure 22.

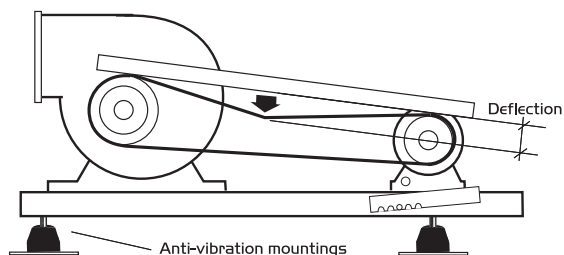

Changing a drive belt

To replace a belt, remove the two bolts from the motor mounting furthest from the fan and slacken the remaining two bolts. Lift the motor plate and remove the belt. Replacing the belt is the reverse of this procedure.

Adjusting drive belt tension

All belt drive units incorporate a belt tensioning facility.

To adjust the belt tension, slacken the pinch bolts on the sides of the motor plate. Use the motor platform pivot adjustment to tighten and loosen the belt.

Clean impellers with a soft brush only, and remove dust/deposits from all internal surfaces including the motor housing,

6.7 General

Inspect all internal and external surfaces to check for corrosion or peeling of painted surfaces.

Thoroughly clean affected areas with a wire brush, apply a coat of zinc rich primer or similar, and re-touch with suitable finishing paint. Ensure tightness of all nuts, bolts, and fixings. Check all components for general condition.

7.0 Service

Service schedule (typical – will depend on site conditions)

	6 MONTHS	12 MONTHS
FILTERS	✓ or	✓
DAMPERS		✓
DAMPER ACTUATORS		✓
BELT DRIVES		✓
FILTER MANOMETER FLUID	✓	
VENT WATER COILS		✓
COIL FINNED SURFACES		✓
CHECK DRAIN LINES + DRIP TRAY	✓	✓
CLEAN & FLUSH DRAIN PANS	Building Schedule ?	✓
NUTS, BOLTS, FIXINGS SECURE		✓
FAN BEARINGS		✓
ELECTRIC HEATERS		✓
ELECTRICAL WIRING		✓
FAN IMPELLER		✓
GENERAL		✓

8.0 Warranty

Ecosmart XBOXER TWB units have a 5 year warranty.

No control units have a 2 year warranty. The first year covers parts and labour and the remaining period covers parts only.

This warranty is void if the equipment is modified without authorisation, is incorrectly applied, misused or not installed commissioned and maintained in accordance with the details contained in this manual and general good practice.

9.0 Spares

Spare parts and replacement components, and general advice are available from the Technical Support department.

Telephone 029 2085 8400
Fax 029 2085 8444

DECLARATION OF INCORPORATION AND INFORMATION FOR SAFE INSTALLATION, OPERATION AND MAINTENANCE

We declare that the machinery named below is intended to be assembled with other components to constitute a system of machinery. The machinery shall not be put into service until the system has been declared to be in conformity with the provisions of the EC Machinery Directive.

Designation of machinery: XBOXER-RAC Run Around Coil

Machinery Types: Heat Recovery



Relevant EC Council Directives: 2006/42/EC (Machinery Directive)

Applied Harmonised Standards: BS EN ISO 12100-1, BS EN ISO 12100-2, EN294, EN60204-1, BS EN ISO 9001

Applied National Standards: BS848 Parts One, Two and Five

Note: All standards used were current and valid at the date of signature.

Signature of manufacture representatives:

Name:	Position:	Date:
1) C. Biggs	 Technical Director	20. 07. 07
2) A. Jones	 Manufacturing Director	20. 07. 07

INFORMATION FOR SAFE INSTALLATION, OPERATION AND MAINTENANCE OF NUAIRE VENTILATION EQUIPMENT

To comply with EC Council Directives 2006/42/EC Machinery Directive and 2004/108/EC (EMC).

To be read in conjunction with the relevant Product Documentation (see 2.1)

1.0 GENERAL

1.1 The equipment referred to in this Declaration of Incorporation is supplied by Nuairé to be assembled into a ventilation system which may or may not include additional components.

The entire system must be considered for safety purposes and it is the responsibility of the installer to ensure that all of the equipment is installed in compliance with the manufacturers recommendations and with due regard to current legislation and codes of practice.

2.0 INFORMATION SUPPLIED WITH THE EQUIPMENT

2.1 Each item of equipment is supplied with a set of documentation which provides the information required for the safe installation and maintenance of the equipment. This may be in the form of a Data sheet and/or Installation and Maintenance instruction.

2.2 Each unit has a rating plate attached to its outer casing. The rating plate provides essential data relating to the equipment such as serial number, unit code and electrical data. Any further data that may be required will be found in the documentation. If any item is unclear or more information is required, contact Nuairé.

2.3 Where warning labels or notices are attached to the unit the instructions given must be adhered to.

3.0 TRANSPORTATION, HANDLING AND STORAGE

3.1 Care must be taken at all times to prevent damage to the equipment. Note that shock to the unit may result in the balance of the impeller being affected.

3.2 When handling the equipment, care should be taken with corners and edges and that the weight distribution within the unit is considered. Lifting gear such as slings or ropes must be arranged so as not to bear on the casing.

3.3 Equipment stored on site prior to installation should be protected from the weather and steps taken to prevent ingress of contaminants.

4.0 OPERATIONAL LIMITS

4.1 It is important that the specified operational limits for the equipment are adhered to e.g. operational air temperature, air borne contaminants and unit orientation.

4.2 Where installation accessories are supplied with the specified equipment e.g. wall mounting brackets. They are to be used to support the equipment only. Other system components must have separate provision for support.

4.3 Flanges and connection spigots are provided for the purpose of joining to duct work systems. They must not be used to support the ductwork.

5.0 INSTALLATION REQUIREMENTS

In addition to the particular requirements given for the individual product, the following general requirements should be noted.

- 5.1 Where access to any part of equipment which moves, or can become electrically live are not prevented by the equipment panels or by fixed installation detail (eg ducting), then guarding to the appropriate standard must be fitted.
- 5.2 The electrical installation of the equipment must comply with the requirements of the relevant local electrical safety regulations.
- 5.3 For EMC all control and sensor cables should not be placed within 50mm or on the same metal cable tray as 230V switched live, lighting or power cables and any cables not intended for use with this product.

6.0 COMMISSIONING REQUIREMENTS

- 6.1 General pre-commissioning checks relevant to safe operation consist of the following:
 - Ensure that no foreign bodies are present within the fan or casing.
 - Check electrical safety. e.g. Insulation and earthing.
 - Check guarding of system.
 - Check operation of Isolators/Controls.
 - Check fastenings for security.
- 6.2 Other commissioning requirements are given in the relevant product documentation.

7.0 OPERATIONAL REQUIREMENTS

- 7.1 Equipment access panels must be in place at all times during operation of the unit, and must be secured with the original fastenings.
- 7.2 If failure of the equipment occurs or is suspected then it should be taken out of service until a competent person can effect repair or examination. (Note that certain ranges of equipment are designed to detect and compensate for fan failure).

8.0 MAINTENANCE REQUIREMENTS

- 8.1 Specific maintenance requirements are given in the relevant product documentation.
- 8.2 It is important that the correct tools are used for the various tasks required.
- 8.3 If the access panels are to be removed for any reason the electrical supply to the unit must be isolated.
- 8.4 A minimum period of two minutes should be allowed after electrical disconnection before access panels are removed. This will allow the impeller to come to rest.

NB: Care should still be taken however since airflow generated at some other point in the system can cause the impeller to "windmill" even when power is not present.
- 8.5 Care should be taken when removing and storing access panels in windy conditions.

Technical or commercial considerations may, from time to time, make it necessary to alter the design, performance and dimensions of equipment and the right is reserved to make such changes without prior notice.



Western Industrial Estate
Caerphilly United Kingdom
CF83 1NA
T: 029 2085 8400
F: 029 2085 8444
E: info@nuaire.co.uk
W: www.nuaire.co.uk