

# TACHO-LED

## Fan Run Indicator

### Installation Instructions

CE The EMC Directive  
2014/30/EU  
The Low Voltage  
Directive  
2014/35/EU

## Description

TACHO-LED is designed to use the tacho feedback from an electronically commutated motor (brushless DC or AC/EC) to show the fan is operating.

When the fan is rotating the LED will flash rapidly. When the fan is stopped; the LED could either be lit permanently or be off completely depending on the position of the magnets.

Two LED are fitted to each TACHO-LED so that one unit can show the status of both fans in a heat-recovery ventilation unit.

Note this device is suitable for selected fans only.

**Please check with our sales office if there is any doubt regarding compatibility with the fan.**

## Dimensions

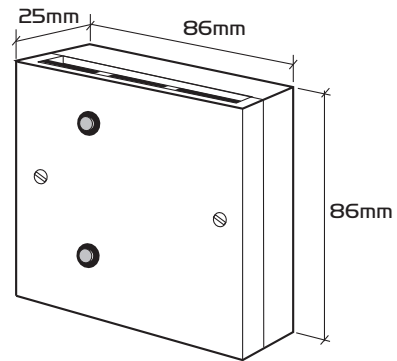

## Installation

**Installed environment:** 0-40°C and up to 90% RH non-condensing.

The installation must be carried out by competent personnel in accordance with all local and national statutory regulation; i.e. IEE, COHSE, HVCA etc.

The unit must be installed indoors, away from a direct source of heat (e.g. radiator), any water spray or steam generating source. The mounting surface must be free from vibrations.

Remove the screws securing the front panel. Mark the fixing-hole positions of the back box. Feed the connecting wires through the hole at the bottom the back box.

Drill and securely fix the back box to the wall using appropriate fasteners (not supplied). Connect the wires to the terminal blocks as shown in the wiring diagram below.

## Warranty

The 3 year warranty starts from the date of delivery and includes parts and labour for the first year. The labour element is subject to full, free and safe access to the equipment as recommended by the CDM regulations. The remaining 2 years covers replacement parts only.

This warranty is void if the equipment is modified without authorisation, is incorrectly applied, misused, disassembled, or not installed, commissioned and maintained in accordance with the details contained in this manual and general good practice.

The product warranty applies to the UK mainland and in accordance with Clause 14 of our Conditions of Sale. Customers purchasing from outside of the UK should contact Nuair International Sales office for further details.

## After Sales Enquiries

For technical assistance or further product information, including spare parts and replacement components, please contact the After Sales Department.

## Wiring

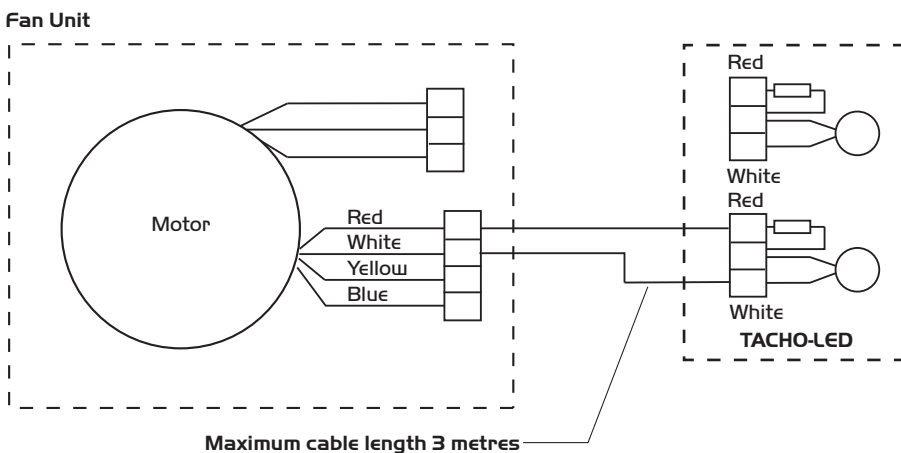

**Telephone**  
**02920 858 400**

Technical or commercial considerations may, from time to time, make it necessary to alter the design, performance and dimensions of equipment and the right is reserved to make such changes without prior notice.