



iSense & iSense-HT

230V Flush Mounted

Domestic Continuous Extract Fans

Installation and Maintenance

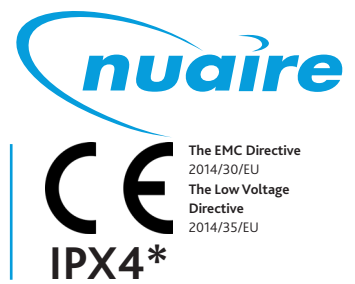

1.0 SAFETY INFORMATION

- The installation must be completed by competent persons in accordance with good industry practice and should conform to all governing and statutory bodies i.e. IEE, CIBSE, HVCA, etc.
- If the environment in which the product is installed also houses a fuel-operating device (water heater, methane stove etc. that is not a “sealed chamber” type), it is essential to ensure adequate air intake, to ensure good combustion and proper equipment operation.
- Ensure adequate air return into the room in compliance with existing regulations in order to ensure proper device operation. Ensure the fans capability by checking the performance fan curve. Flexible ducting is not recommended.
- Disconnection from the supply mains must be incorporated within the fixed wiring in accordance with the wiring regulations and shall have a minimum contact separation of 3mm in accordance with the latest edition of the IEE Wiring Regulations.
- In case of window installation it is necessary to use the appropriate window kit, which is not included. Glass thickness from 11mm to 35mm.
- This appliance can be used by children aged from 8 years and above and persons with reduced physical, sensory or mental capabilities or lack of experience and knowledge if they have been given supervision or instruction concerning use of the appliance in a safe way and understand the hazards involved. Cleaning and user maintenance should not be made by children without supervision. The unit is not intended for use by persons (including children) with reduced physical, sensory or mental capacities or those with a lack of experience and knowledge, unless they have been given supervision or instruction concerning use of the unit from a person responsible for their safety. Children should be supervised to ensure that they do not play with the unit.

2.0 INTRODUCTION

These high quality extractor fans are mechanical ventilation units designed to ensure air extraction in small / medium sized rooms. The units are suitable for air discharge directly to the outside or in the presence of short ducted system.

Please read these instructions carefully **before** installing the fan unit. Failure to comply with these instructions could reduce both the life and performance of the product and may invalidate the warranty. Nuair assume no responsibility for damage to persons or property resulting from failure to observe the regulations contained in this booklet.

This appliance can be used by children aged from 8 years and above and persons with reduced physical, sensory or mental capabilities or lack of experience and knowledge if they have been given supervision or instruction concerning use of the appliance in a safe way and understand the hazards involved. Cleaning and user maintenance should not be made by children without supervision. The unit is not intended for use by persons (including children) with reduced physical, sensory or mental capacities or those with a lack of experience and knowledge, unless they have been given supervision or instruction concerning use of the unit from a person responsible for their safety. Children should be supervised to ensure that they do not play with the unit.

2.1 Unit Features

- Construction Material: High quality, impact and UV-resistant ABS.
- Unit fascia is removable for cleaning without the use of tools.
- Single phase DC brushless motor with locked rotor protection.
- Motor mounted on high quality ball bearings.
- The fan is double insulated: no earth connection is required.
- Trickle speed selectable: 4 or 6 l/s.
- Option to boost through a Switch Live (SL) connection. Boost speed selectable: 6, 8 or 13 l/s.
- Installation type selection available (through wall or ducted).
- Timer and integral humidistat.
- Constant volume facility.
- IPX4 rating with wall installation.
- Power supply 220V to 240V~ 50/60Hz.
- Operating temperature: 0°C to +40°C

2.2 Code Descriptions

UNIT	DESCRIPTION
iSense	230V Decentralised Mechanical Extract Ventilation Fan
iSense-HT	230V Decentralised Mechanical Extract Ventilation fan with Humidistat Override

3.0 DIMENSIONS

Figure 1. iSense Dimensions

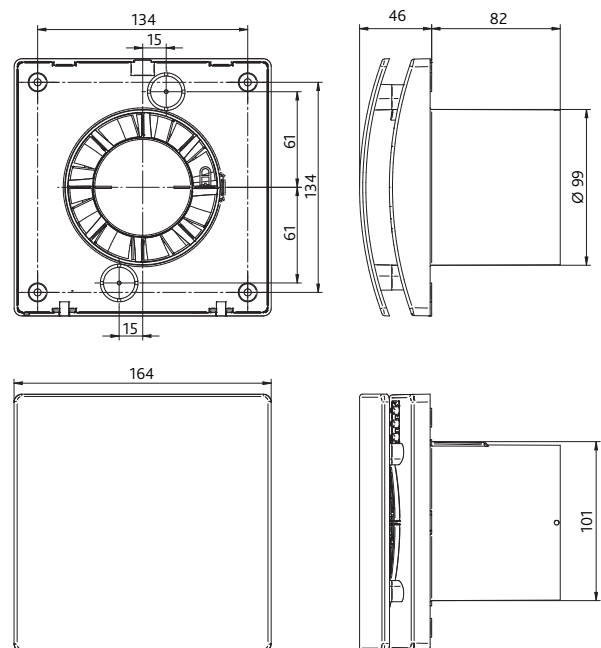

IMPORTANT

Isolation - Before commencing work, make sure that the unit, switched live and any controls are electrically isolated from the mains supply. If in doubt, consult an electrician.

Installation and Maintenance

4.0 IMPORTANT NOTES TO INSTALLERS

Before commencing any work read the following instructions carefully and ensure you have the necessary competency to complete the work safely.

The installation must be completed by competent persons in accordance with good industry practice and should conform to all governing and statutory bodies i.e. IEE, CIBSE, HVCA, etc.

If the environment in which the product is installed also houses a fuel-operating device (water heater, methane stove etc., that is not a "sealed chamber" type), it is essential to ensure adequate air intake, to ensure good combustion and proper equipment operation.

Ensure adequate air return into the room in compliance with existing regulations in order to ensure proper device operation. Ensure the fans capability by checking the performance fan curve. Flexible ducting is not recommended.

Ensure that the fan or exhaust grille are not obstructed, to guarantee optimum air passage.

5.0 INSTALLATION

5.1 Wall Installation

1. Select a suitable position for the fan that keeps the duct as short and as straight as possible (ideally on a wall within 400mm of the ceiling).
2. Cut a hole in the wall to suit the outside diameter of the ducting or wall-liner. Install the duct or wall-liner taking care to seal at both ends between it and the wall using proprietary waterproof mastic.
3. Remove the magnetic fascia of the fan by pulling the fascia straight off.
4. Loosen the front fan plate by unscrewing the front fixing screws (Figure 2).
5. Use a small flat-head screwdriver to release the retaining clips between the front fan plate and fan backplate. Remove front fan plate (Figure 3).
6. Position the fan in the duct and mark the four retaining screw positions through the fan backplate. Fit screw anchors suitable for the wall construction.
7. If installing via recessed cable entry, drill a hole of sufficient diameter in the fan backplate to fit the rubber grommet and allow the supply cable to pass through the backplate (Figure 4).
8. Screw the backplate to the wall in positions marked earlier.
9. For surface cable entry remove the white rubber cable gland (Figure 5) and cable clamp from the backplate, cut the cable gland to the required diameter and thread the supply cable through the gland. Slot the gland into place in the fan backplate.
10. For recessed cable entry, fit the rubber grommet into the hole drilled in step 7 and thread the supply cable through the grommet.
11. Complete the wiring by following the relevant wiring diagram in section 6.0. Ensure that the cable gland is slotted into place in the backplate, for surface cable entry the cable is to be secured via the cable clamp (Figure 6 & Figure 7).
12. Replace the front fan plate, an audible "Click" should be heard when the front cover clips into place. Fix with the screws provided, and replace the fascia.

Figure 2. Unscrewing front fixing screws.

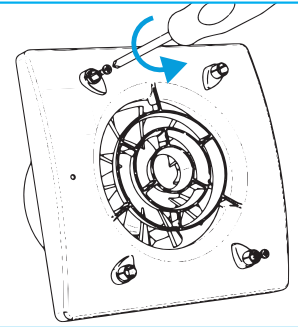

Figure 3. Releasing retaining clips with flat-head screwdriver.

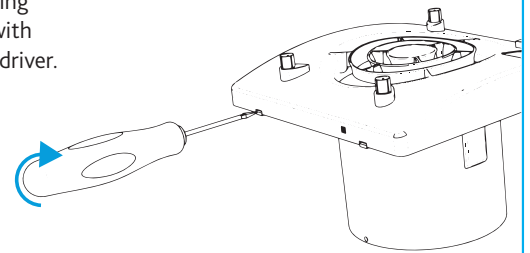

Figure 4. Drilling fan backplate for recessed cable entry.

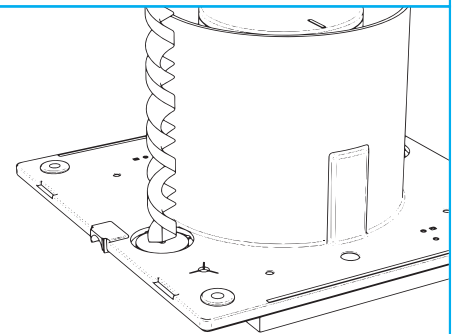

Figure 5. Removing cable gland for surface cable entry.

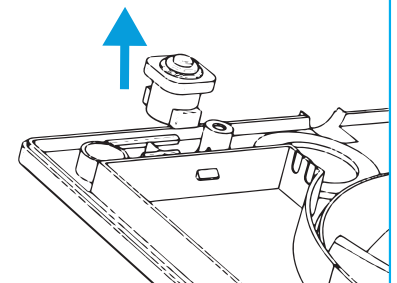

Figure 6. Cable installation for surface cable entry.

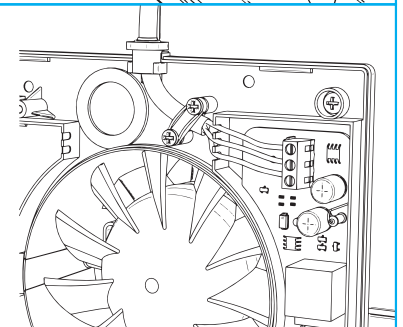
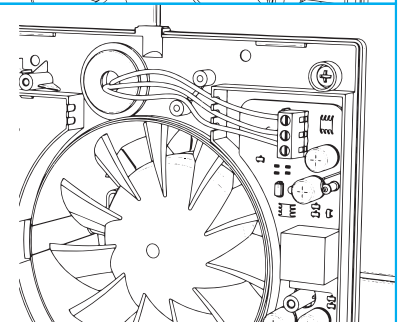

Figure 7. Cable installation for recessed cable entry.



6.0 WIRING

Disconnection from the supply mains must be incorporated within the fixed wiring in accordance with the wiring regulations and shall have a minimum contact separation of 3mm in accordance with the latest edition of the IEE Wiring Regulations.

Before connecting the product to the power supply or the power outlet, ensure that:

- The data plate (voltage and frequency) correspond to those of the electrical mains.
- The electrical power supply/socket is adequate for maximum unit power. If not, contact a qualified technician.

The electrical system to which the unit is connected must comply with regulations.

6.1 iSense Wiring

Figure 8. iSense Wiring

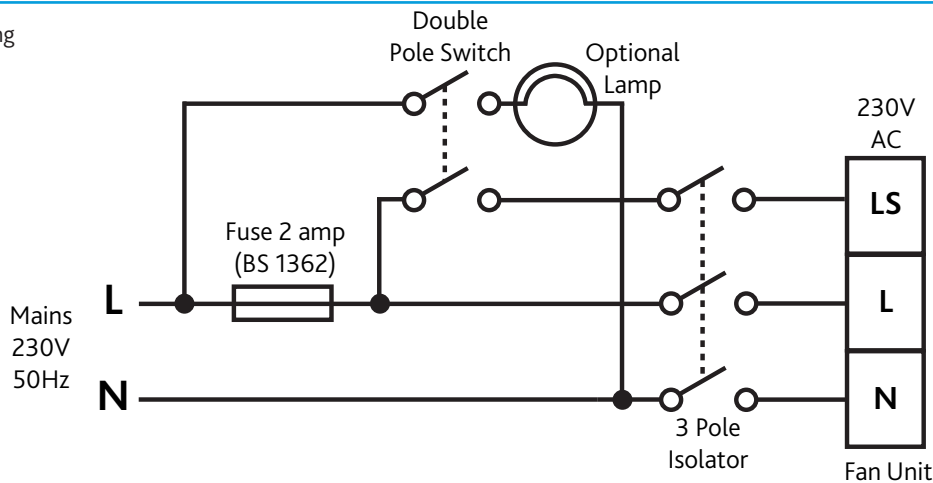

IMPORTANT

Isolation: Before commencing work, make sure that the unit, switched live and any controls are electrically isolated from the electric supply. If in doubt, consult an electrician.

IMPORTANT

Do not over tighten terminal block screws, maximum torque 0.15Nm

7.0 OPERATION

Read this manual carefully before operating the product and keep it in a safe place for reference.

7.1 Description of Operation

Upon power up and in the absence of an active SL, the unit will run continuously at a settable trickle speed of between 4-6 l/s.

If the humidistat (where applicable) is activated, the unit works at 'boost' speed.

If the SL or remote is activated, the unit runs at 'boost' speed.

After the remote switch is turned off, the fan continues to run at 'boost' speed for a settable period of time, then it returns to selected 'trickle' speed.

The run-on timer function is activated only if the SL has been on for at least 3 minutes.

7.2 Trickle and Boost Speeds

Upon power up and in the absence of an active SL, the unit will run continuously at a settable trickle speed of between 4-6 l/s.

The unit will run at a settable boost speed of between 6-13 l/s when either of the below conditions have been met.

- The humidistat has been activated.
- The run-on timer has been activated.
- The SL (Switched Live) has been activated.

7.2.1 Setting Trickle and Boost Speeds (see Figure 9)

The trickle and boost speed settings on the unit can be selected by setting DIP switches 2 & 3 to the required positions (see the table below).

Criteria	DIP 2	DIP 3	Setting
Speed Setting	OFF	OFF	Sanitary Accommodation 4l/s Trickle, 6l/s Boost
	OFF	ON	Bathroom (DEFAULT) 4l/s Trickle, 8l/s Boost
	ON	OFF	Utility Room 6l/s Trickle, 8l/s Boost
	ON	ON	Kitchen 6l/s Trickle, 13l/s Boost

7.3 Constant Flow Operation

The unit can run at a constant speed.

7.3.1 Choosing Constant Flow

Select constant flow on the unit by setting DIP switch 4 to the required position (see the table below).

Criteria	DIP 4	Setting
Constant Flow Operation	OFF	Disabled
	ON	Enabled (DEFAULT)

7.4 Installation Type

The unit will scale its speed to obtain the air flow rates given for the trickle and boost speeds based on installation type.

Installation and Maintenance

'Through Wall' installation is typically for fans that are mounted on an external wall / window and extract direct to the outside.

An 'In Room' installation is typically for fans that are mounted on the ceiling or internal wall and which are ducted to the outside. Note, that the unit will run at a higher RPM when an 'In Room' installation is selected.

7.4.1 Setting Installation Type

Select the installation type on the unit by setting DIP switch 1 to the required position (see the table below).

Criteria	DIP 1	Setting
Installation Setting	OFF	Through Wall (DEFAULT)
	ON	In Room

7.5 Humidity (Where Applicable)

An integral humidistat is included with the unit and has an adjustable threshold of 50-95% (Default = 75%). If the humidistat is activated, the unit runs at boost speed and continues running for a fixed 5 minute run-on cycle after humidity levels drop below the selected threshold.

7.5.1 Setting the Humidistat (Where Applicable)

Set the humidistat setting on the unit by rotating the pot marked 'HY' to obtain the desired humidity set point.

7.6 Run-on Timer

An integral run-on timer is included with the unit which is easily adjustable between 1-25 minutes (Default = 15 mins). When the SL is deactivated, the unit runs at boost speed and continues running for a fixed time run-on cycle according to the setting of the run-on timer.

After the run-on time has expired, the unit returns to trickle speed.

If the SL does not stay active for 3 minutes run-on is not performed.

7.6.1 Setting the Run-on Time

Set the run-on time setting on the unit by rotating the pot marked 'TIMER' to obtain the desired run-on time set point.

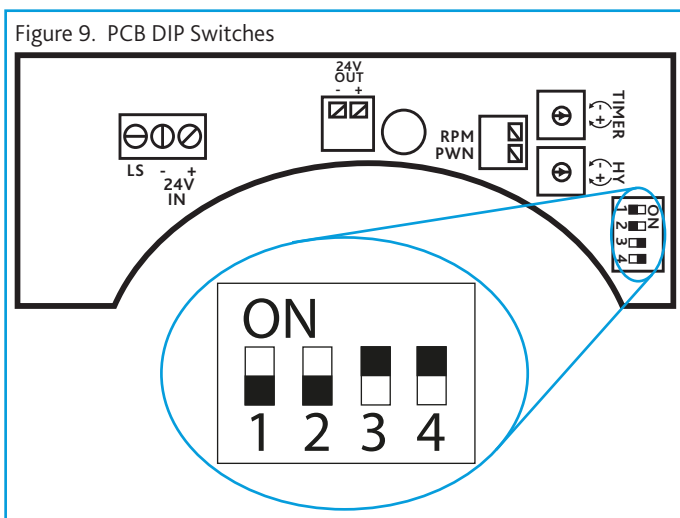

7.7 Decentralised Mechanical Extract Ventilation (dMEV)

iSense units are suitable for decentralised mechanical extract ventilation and are recognised by the Government's Standard Assessment Procedure (SAP) under the Product Characteristic Database (PCDB).

8.0 MAINTENANCE

Before any maintenance or cleaning operation, switch off the fan and disconnect from the power supply.

The magnetic front cover can be removed and cleaned with water and a mild detergent using a soft cloth and the motor fan assembly can be cleaned with a dry brush or dry cloth. Any other maintenance or cleaning should be carried out by properly qualified personnel.

Ensure the unit does not come into contact with any kind of liquid or solvent. If this should occur, contact a qualified technician before reassembling the fan.

NOTE: The motor does not require lubrication as it is of the maintenance free "sealed for life" type.

9.0 WARRANTY

The 5 year warranty starts from the day of delivery and includes parts and labour for the first year. The remaining period covers replacement parts only.

This warranty is void if the equipment is modified without authorisation, is incorrectly applied, misused, disassembled, or not installed, commissioned and maintained in accordance with the details contained in this manual and general good practice.

The product warranty applies to the UK mainland and in accordance with Clause 14 of our Conditions of Sale.

If any abnormalities in operation are detected, disconnect the unit from the supply and contact a qualified technician immediately. Use original spare parts only for repairs.

If the supply cord is damaged, it must be replaced by the manufacturer, its service agent or similarly qualified persons in order to avoid a hazard.

10.0 DISPOSAL AND RECYCLING

Information on disposal of units at the end of life.

This product complies with EU Directive 2002/96/EC.

The symbol of the crossed-out dustbin indicates that this product must be collected separately from other waste at the end of its life. The user must, therefore, dispose of the product in question at suitable electronic and electro-technical waste disposal collection centres, or else send the product back to the retailer when purchasing a new, equivalent type unit.

Separate collection of decommissioned equipment for recycling, treatment and environmentally compatible disposal helps to prevent negative effects on the environment and on health and promotes the recycling of the materials that make up the equipment.



Improper disposal of the product by the user may result in administrative sanctions as provided by law.

11.0 AFTER SALES ENQUIRIES

For technical assistance or further product information, including spare parts and replacement components, please contact the After Sales Department.

Telephone 02920 858 400
aftersales@nuaire.co.uk

Technical or commercial considerations may, from time to time, make it necessary to alter the design, performance and dimensions of equipment and the right is reserved to make such changes without prior notice.